

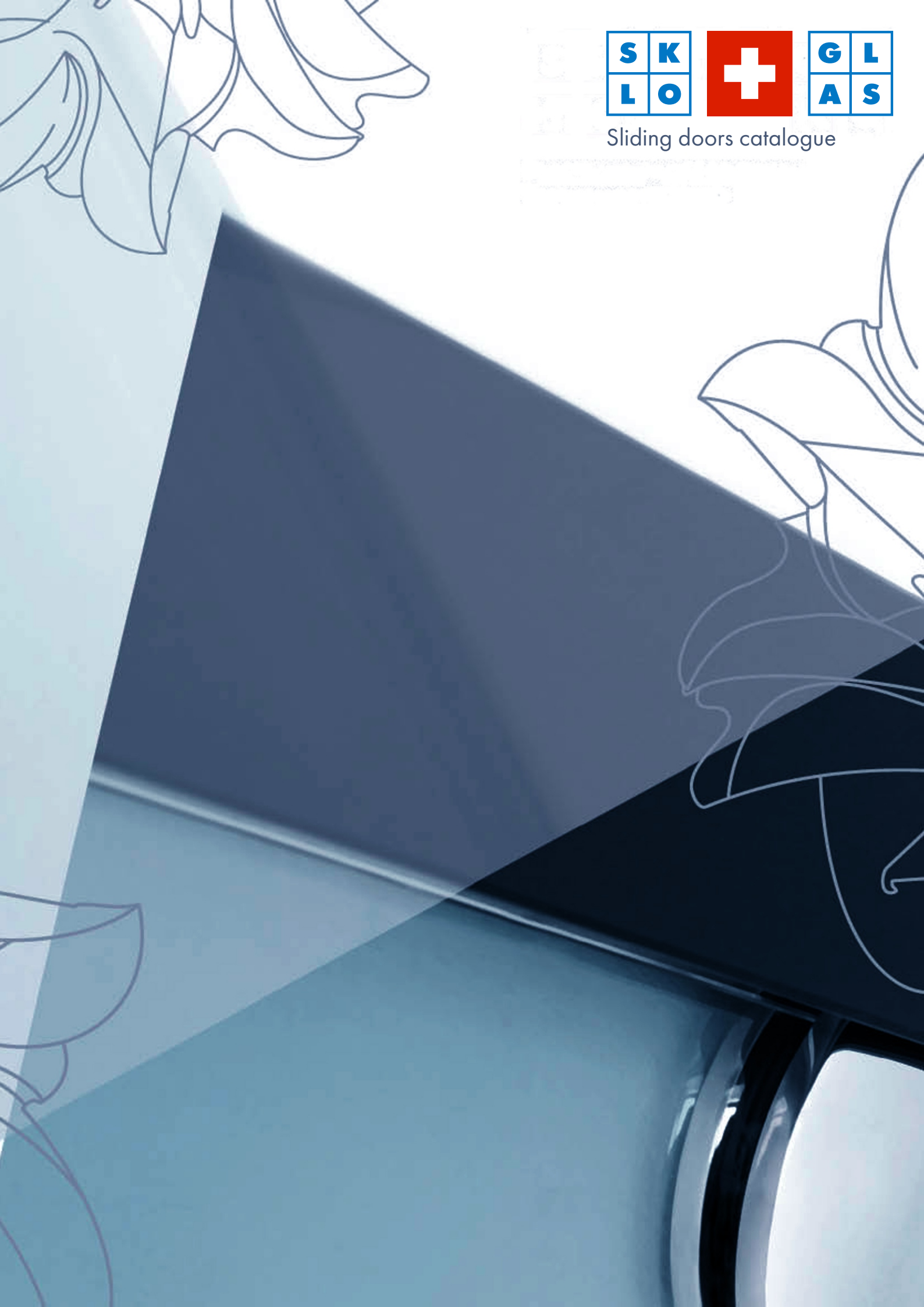

Sliding doors catalogue



Content

| | |
|--|-------|
| 1. Content | 2 |
| 2. Sliding system with covered guide S-1000 Clips | 3-7 |
| 3. Sliding system with covered guide S-1200 | 7-8 |
| 4. Sliding system with covered guide S-1300 | 10-12 |
| 5. Sliding system with covered guide S-2000 | 13-20 |
| 6. Sliding system with covered guide on rollers S-2000 | 14-15 |
| 7. Sliding system with covered guide S-2000 on clamps | 16-17 |
| 8. Sliding system with covered guide S-2000 with panel shift | 18-20 |
| 9. Sliding system with covered guide S-4000 | 21-23 |
| 10. Sliding system with covered guide S-4100 | 25-29 |
| 11. Sliding system with covered guide S-500 | 30-33 |
| 12. Handles for sliding systems SKLO+GLAS | 35 |
| 13. Measuring sheet for sliding doors | 36 |

Single-plane sliding system with covered guide S-1000 Clips

Doors opening diagram

1-panel sliding system

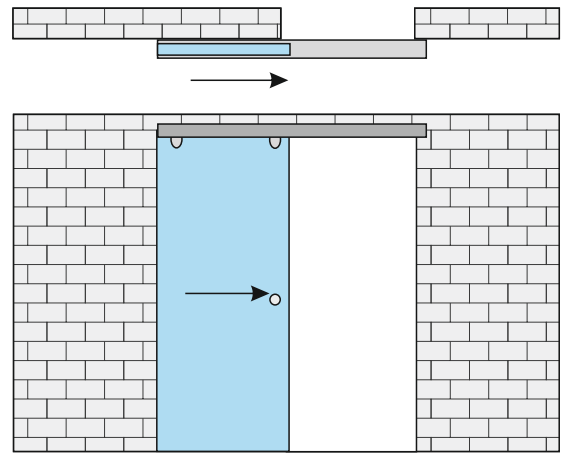
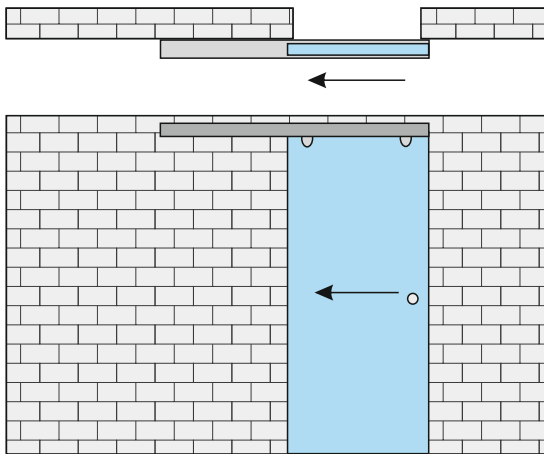

2-panel sliding system

a) with one mobile panel and one fixed panel

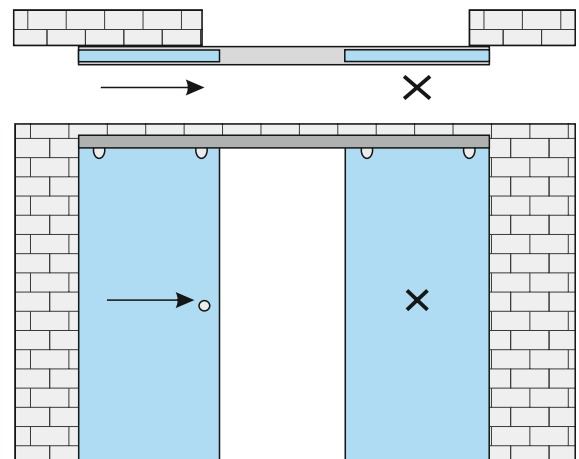
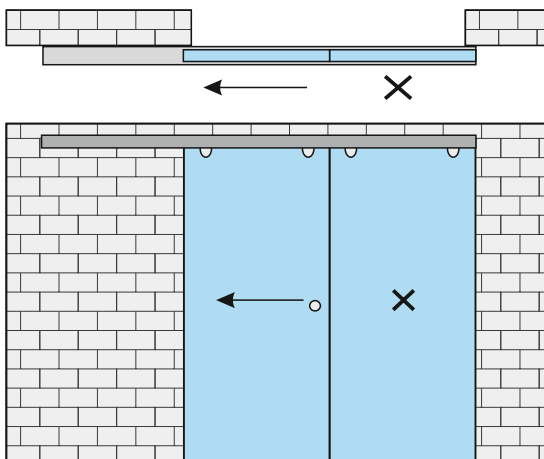

b) with two mobile panels

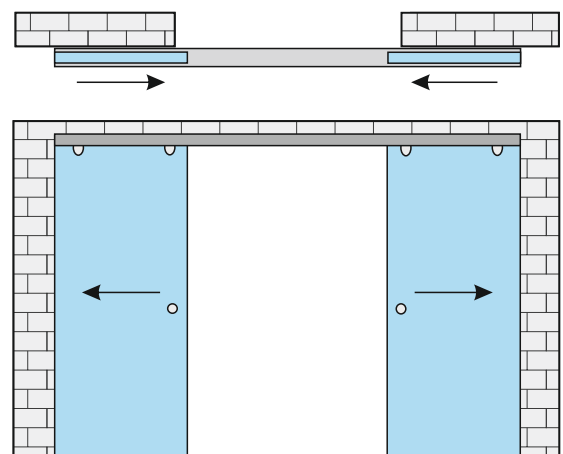
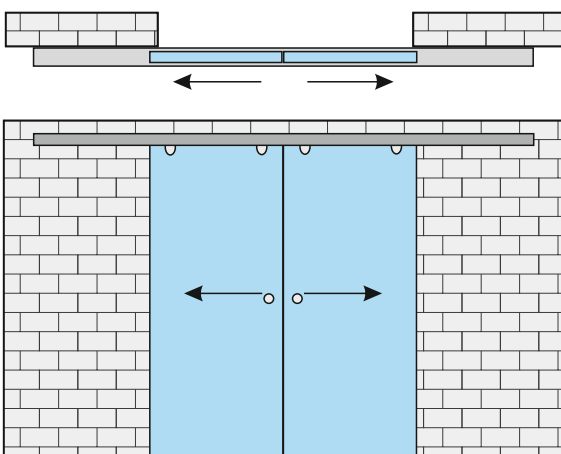

Single-plane sliding system with covered guide S-1000 Clips

Assembly drawings System elements

Pic. 1 Wall mounting

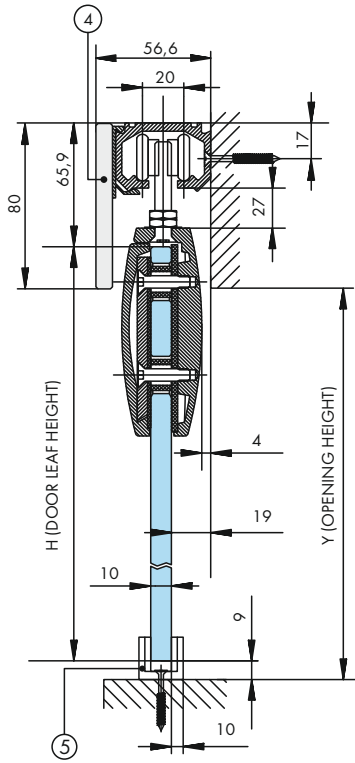

Pic. 2 Ceiling mounting

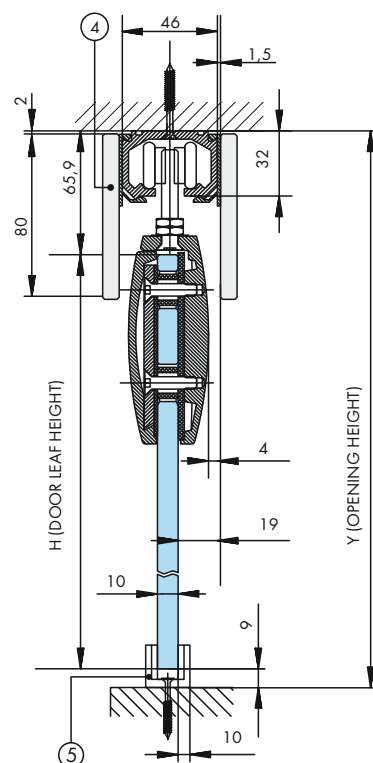

Pic. 3 Assembled system

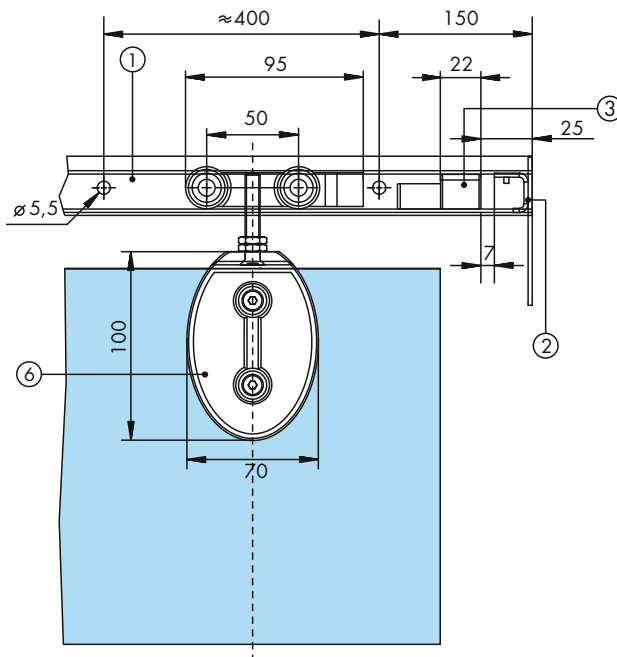

Producer reserves the right to introduce changes in delivery set*

1. Guide track

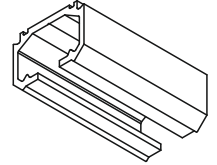

2. End cap

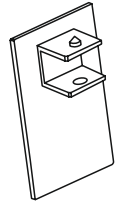

3. Stopper with fixing

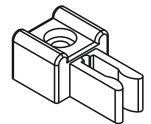

4. Front glass panel

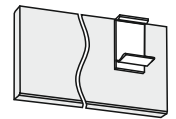

5. Floor guide

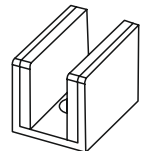

6. Carriage with oval clip

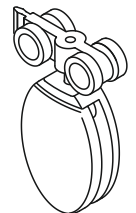

6.1. Round clip



6.2. Vertical clip

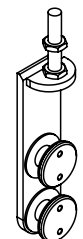

Single-plane sliding system with covered guide S-1000 Clips

Design parameters

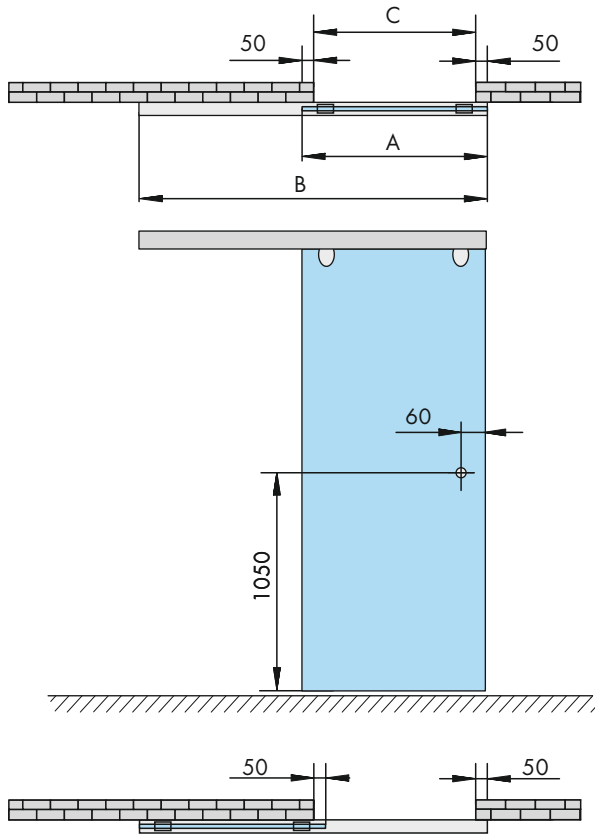

1-panel sliding system

$$A = C + 100$$

$$B = 2C + 100$$

$$H \text{ (wall mounting)} = Y + 5$$

$$H \text{ (ceiling mounting)} = Y - 75$$

C – opening width; A – door leaf width;
B – guide track length;
H – door leaf height; Y – opening height.

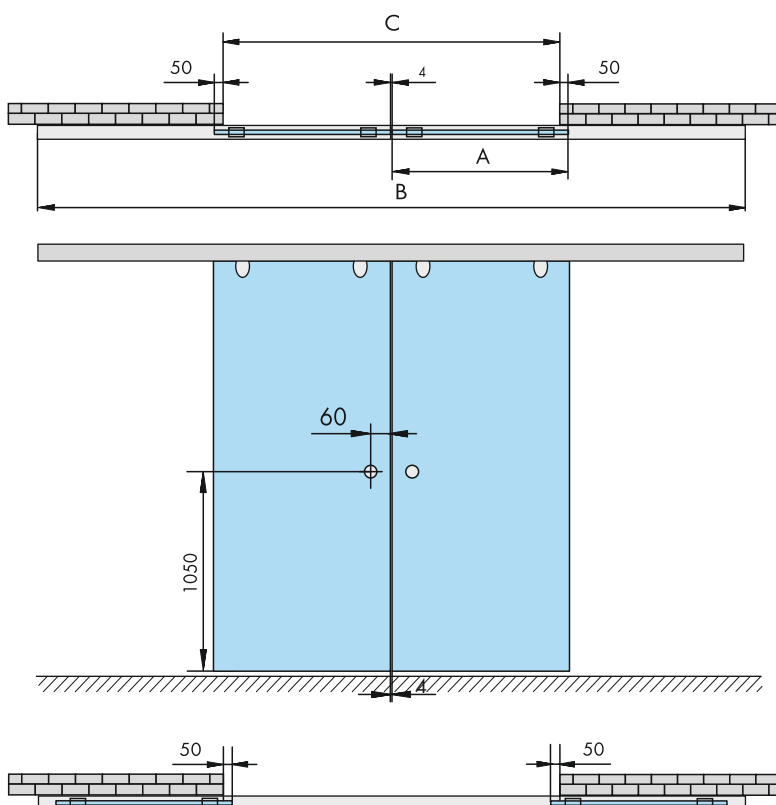

2-panel sliding system

$$A = (C - 4) / 2 + 50$$

$$B = 2C - 4$$

$$H \text{ (wall mounting)} = Y + 5$$

$$H \text{ (ceiling mounting)} = Y - 75$$

C – opening width; A – door leaf width;
B – guide track length;
H – door leaf height; Y – opening height.

Single-plane sliding system with covered guide S-1000 Clips

Clips

Clips for sliding systems

Vertical clip



graphite

Drillings layout for clips

Vertical clip

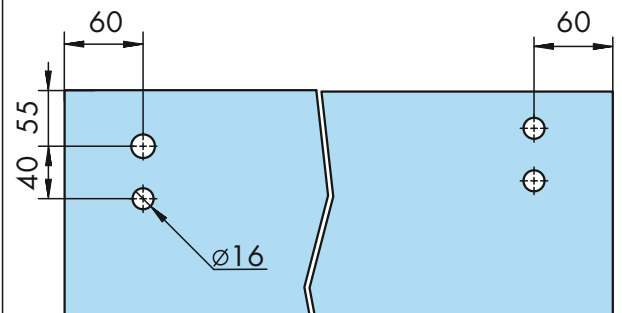

Round clip

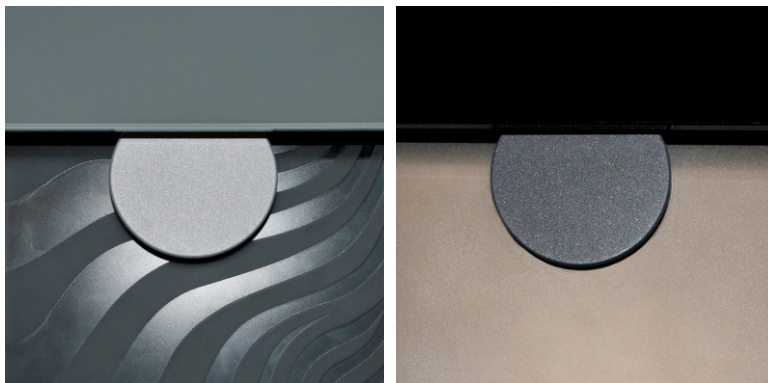

Grey

Graphite

Round clip

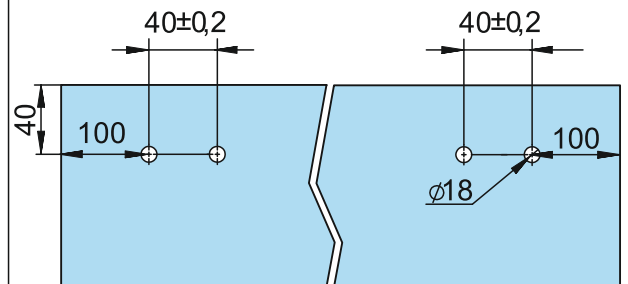

Oval clip



nickel polished

chrome polished

Oval clip

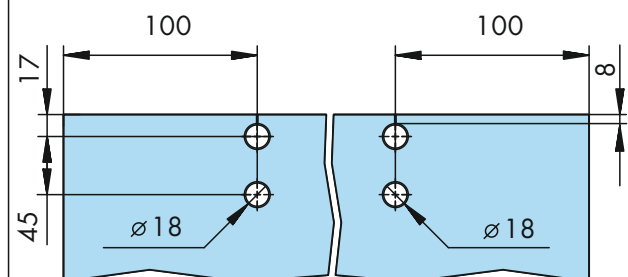

Sliding system with covered guide S-1200

Doors opening diagram

2-panel sliding system

a) mounting in opening:

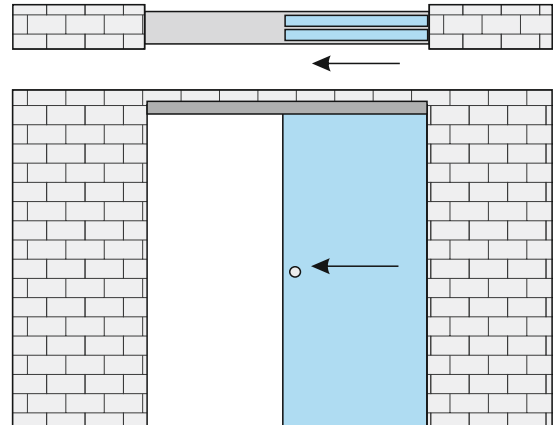
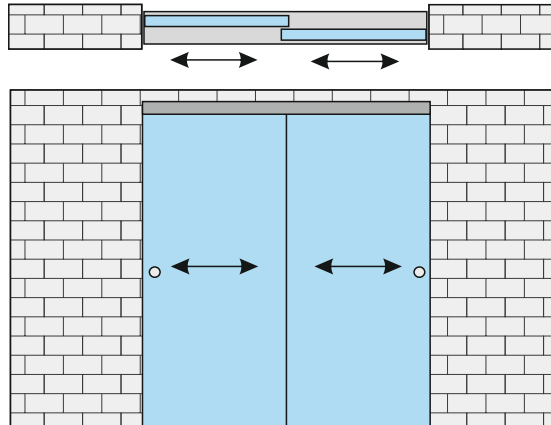

b) mounting on opening

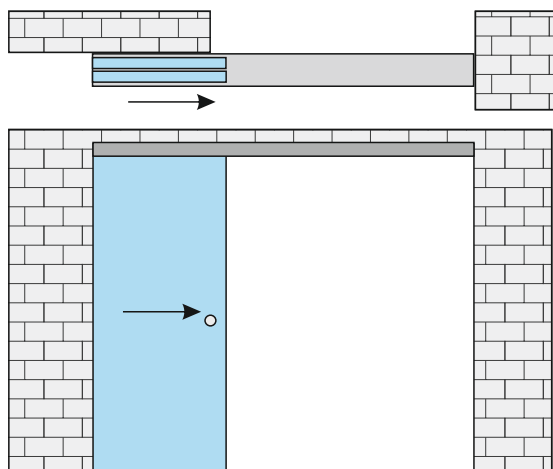
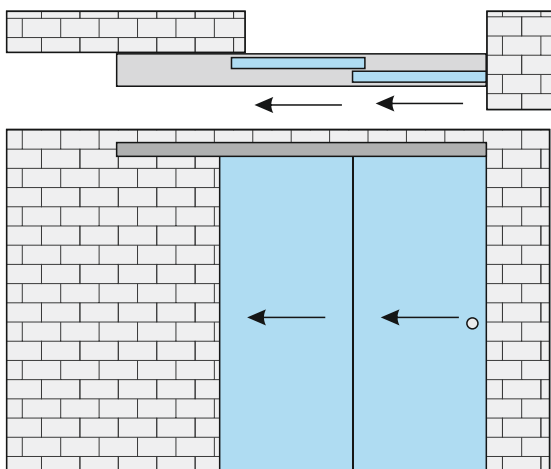

4-panel sliding system

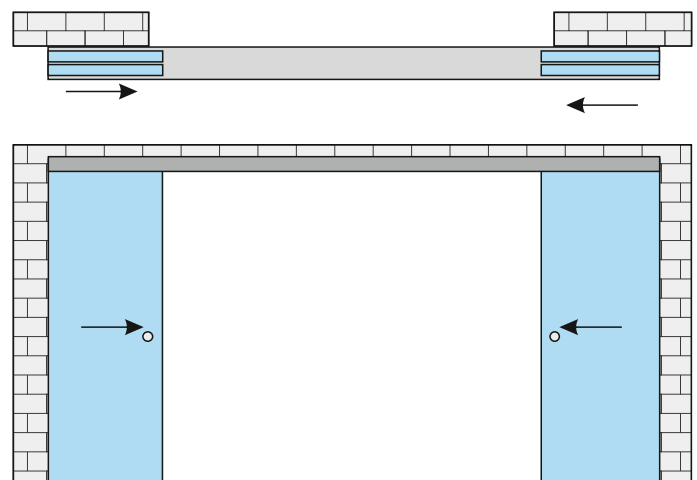
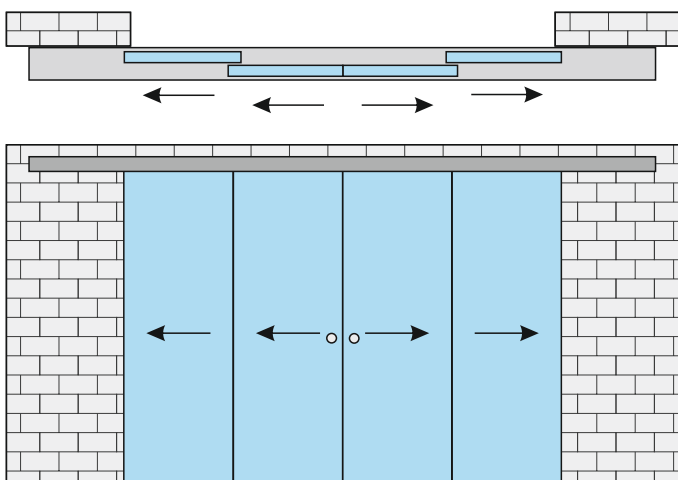

Sliding system with covered guide S-1200

Assembly drawings System elements

Pic.1 Fasteners disposition layout



Pic.2 Wall mounting

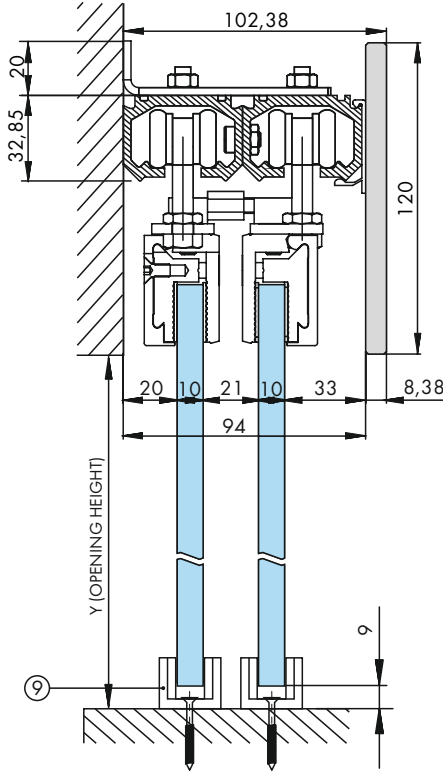

Pic.3 Ceiling mounting

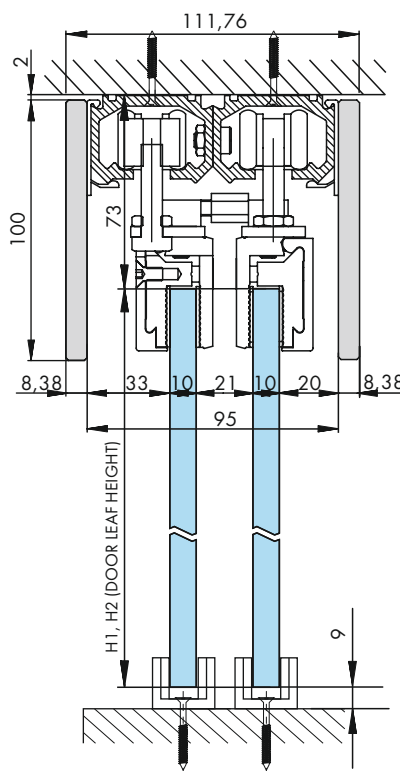

Pic.4 Assembled system

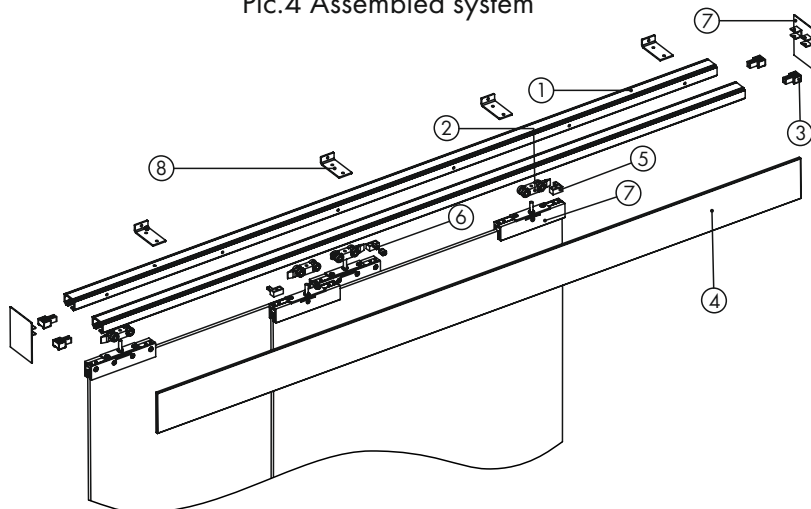

1. Guide track

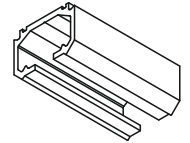

2. Carriage

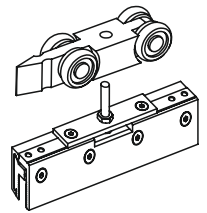

3. Stopper with fixing

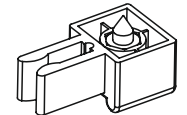

4. Front glass panel

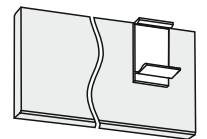

5. Side support

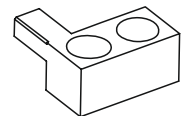

6. Telescopic holder with cover

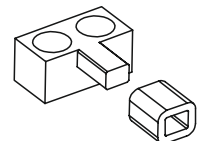

7. End cap

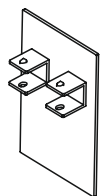

8. Fastening angle (for wall mounting version)

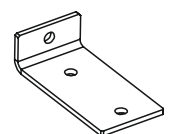

9. Floor guide

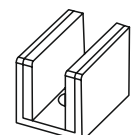

Sliding system with covered guide S-1200

Design parameters

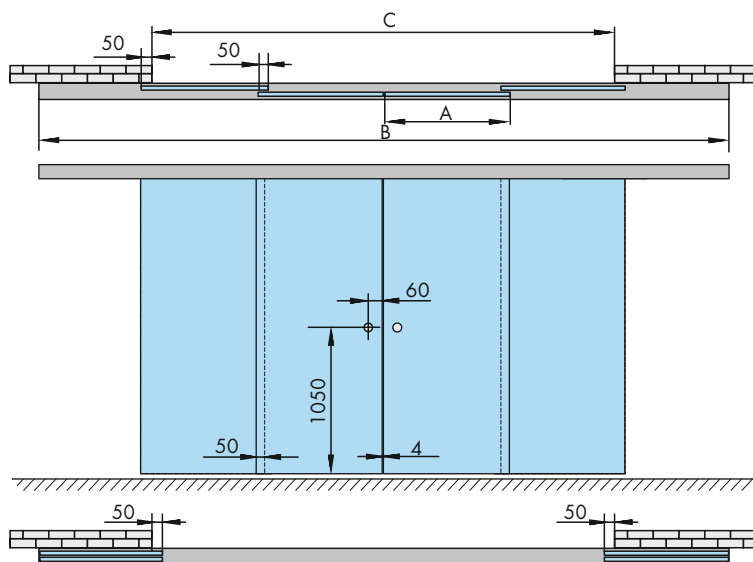

4-panel sliding system mounting on opening:

$$A = C/4 + 49$$

$$B = 1,5C - 2$$

$$H \text{ (wall mounting)} = Y + 18$$

$$H \text{ (ceiling mounting)} = Y - 82$$

C – opening width;
A – door leaf width;
B – guide track length;
H – door leaf height;
Y – opening height.

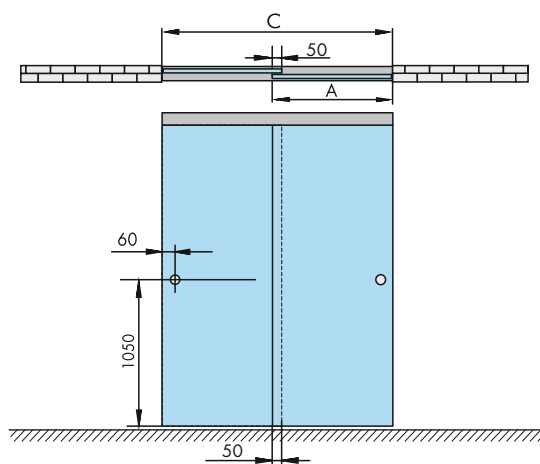

2-panel sliding system mounting in opening:

$$A = C/2 + 23$$

$$B = C - 4$$

$$H = Y - 82$$

C – opening width;
A – door leaf width;
B – guide track length;
H – door leaf height;
Y – opening height.

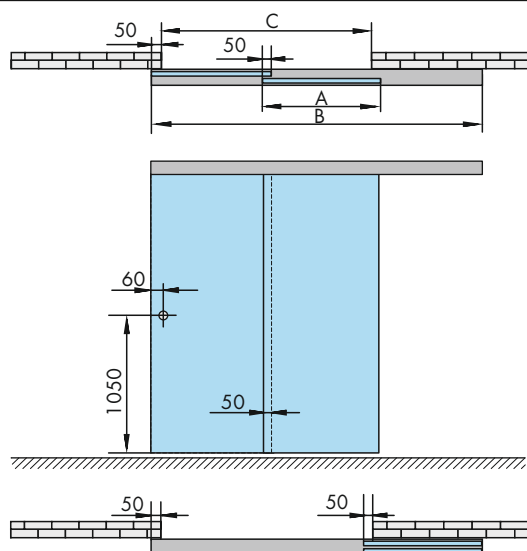

2-panel sliding system mounting on opening:

$$A = C/2 + 75$$

$$B = 1,5C + 75$$

$$H \text{ (wall mounting)} = Y + 18$$

$$H \text{ (ceiling mounting)} = Y - 82$$

C – opening width;
A – door leaf width;
B – guide track length;
H – door leaf height;
Y – opening height.

Sliding system with covered guide S-1300

Doors opening diagram

Three panels:

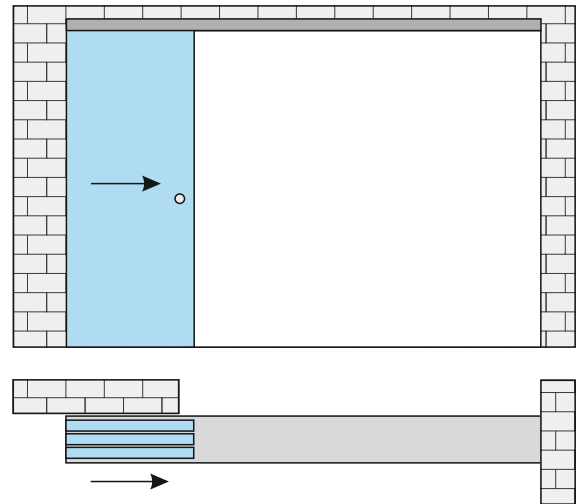
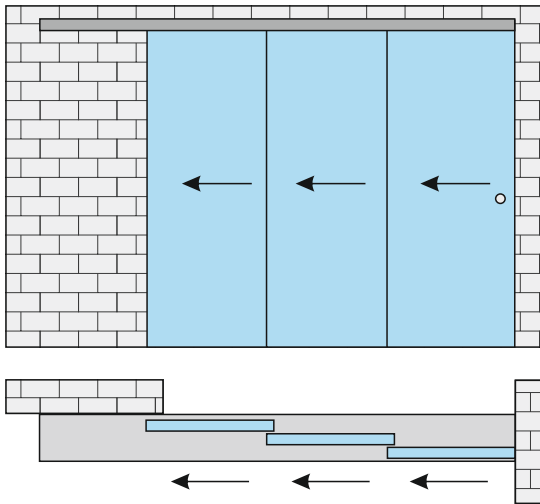

Six panels:

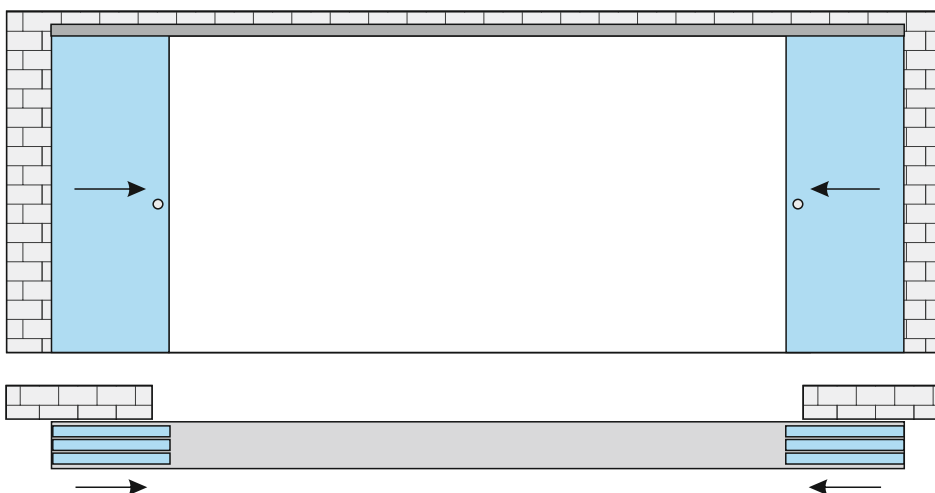
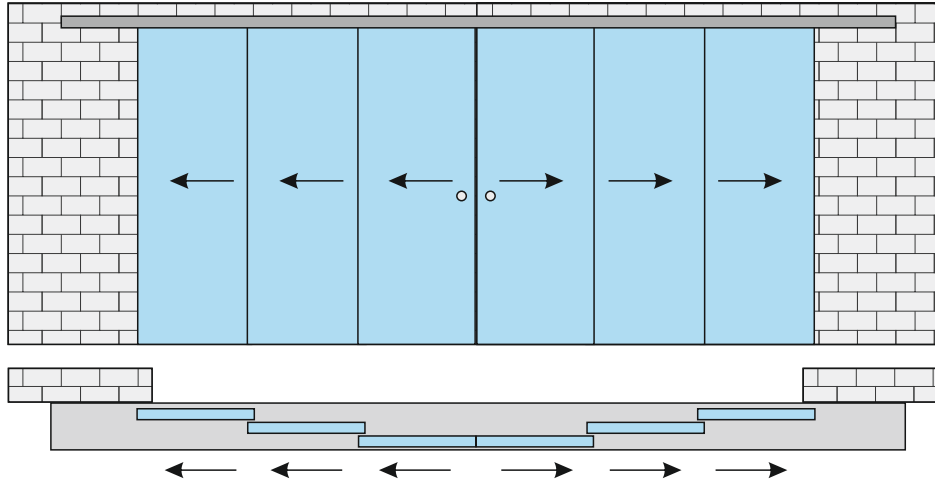

Sliding system with covered guide S-1300

Assembly drawings

Pic.1 Fasteners disposition layout



Pic.2 Wall mounting

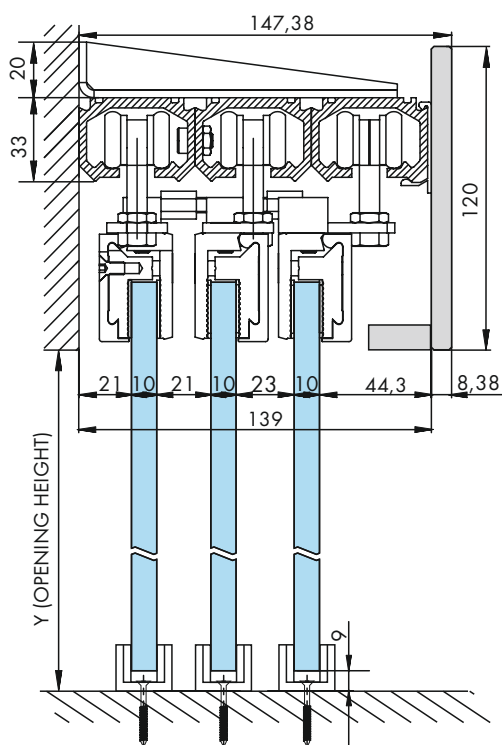

Pic.3 Ceiling mounting

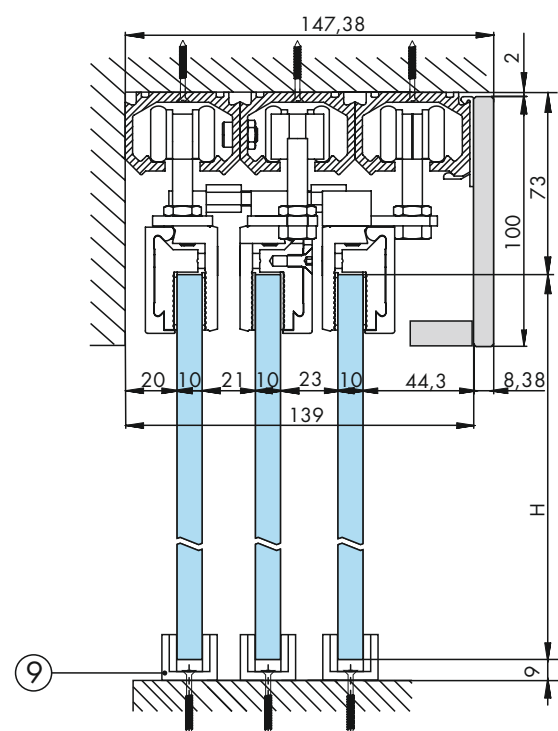

Pic.4 Assembled system

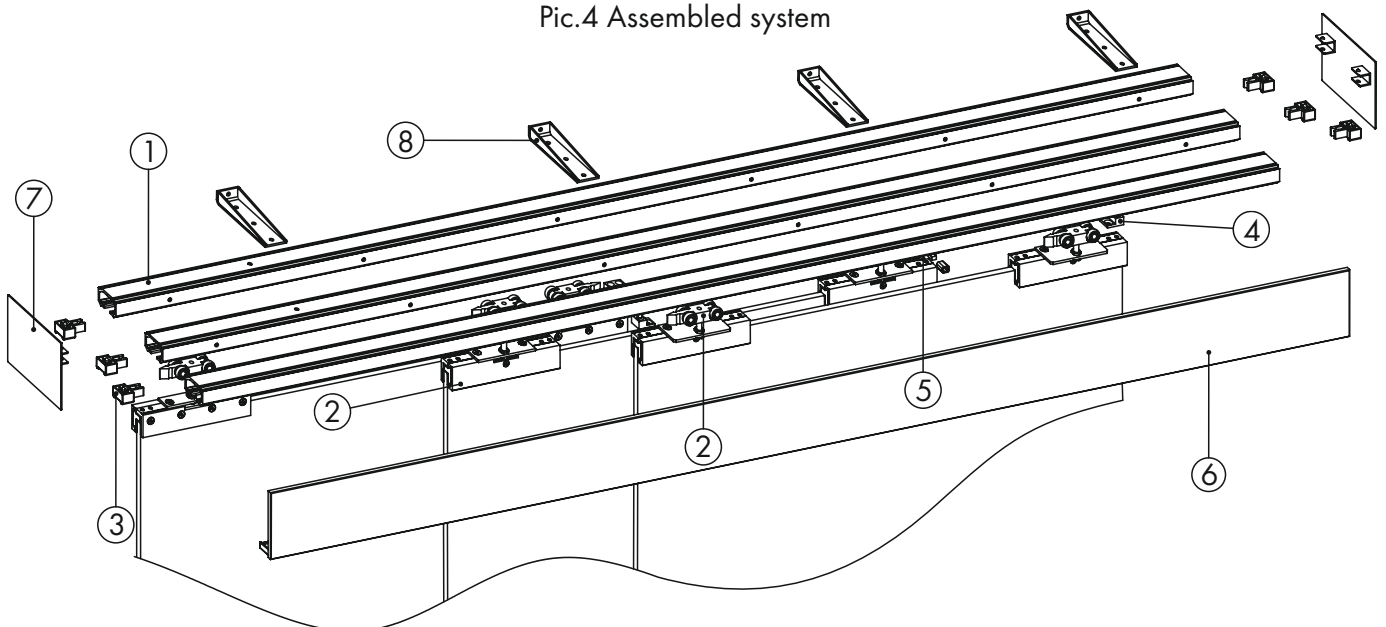

| Sliding system with covered guide S-1300 | | System elements Design parameters |
|--|--|---|
| 1. Guide track | | <p>6-panel system</p> <p> $A = (C - 4) / 6 + 50$ $B = C + 2A - 100$ H (wall mounting) = $Y + 18$ H (ceiling mounting) = $Y - 82$ C – opening width; A – door leaf width; B – guide track length; H – door leaf height; Y – opening height </p> |
| 2. Carriage | | |
| 3. Stopper with fixing | | |
| 4. Side support | | |
| 5. Telescopic holder with cover | | |
| 6. Front glass panel | | |
| 7. End cap | | |
| 8. Fastening angle (for wall mounting version) | | |
| 9. Floor guide | | |
| | | <p>3-panel system</p> <p> $A = C / 3 + 50$ $B = 4A - 200$ H (wall mounting) = $Y + 18$ H (ceiling mounting) = $Y - 82$ C – opening width; A – door leaf width; B – guide track length; H – door leaf height; Y – opening height. </p> |

Sliding system with covered guide S-2000

Doors opening diagram

2-panel system:

a) mounting on opening:

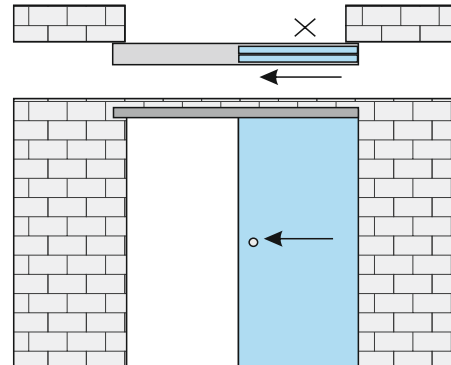
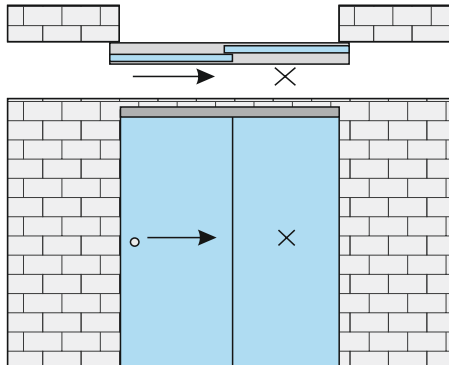

b) mounting in opening:

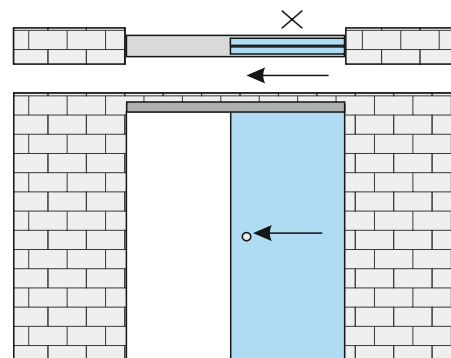
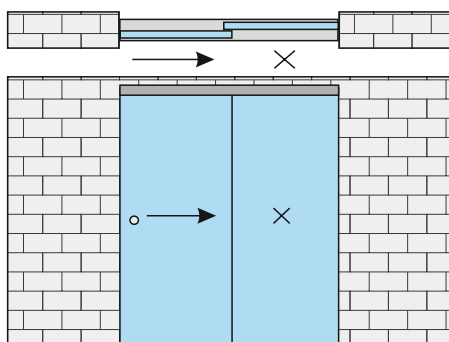

4-panel system:

a) mounting on opening:

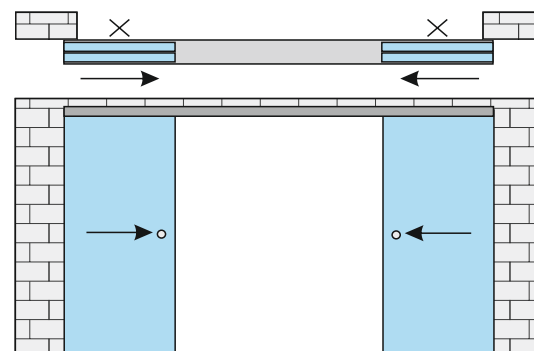
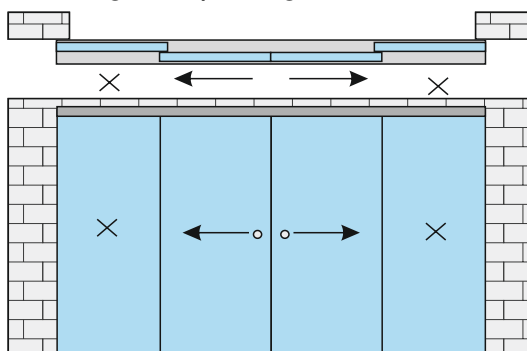

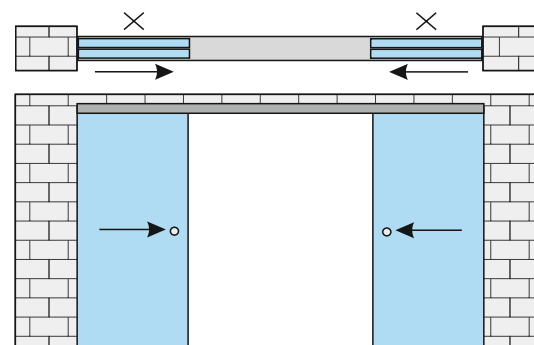
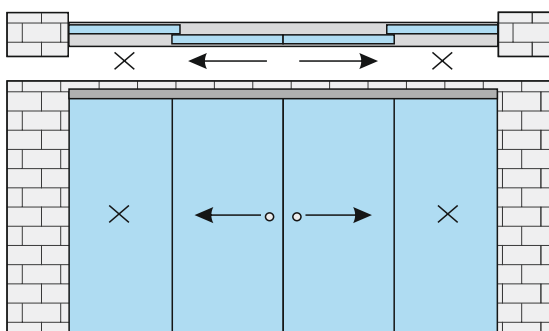

b) mounting in opening:

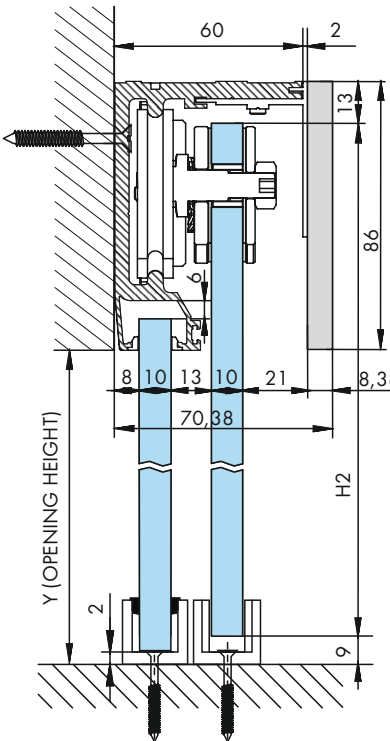
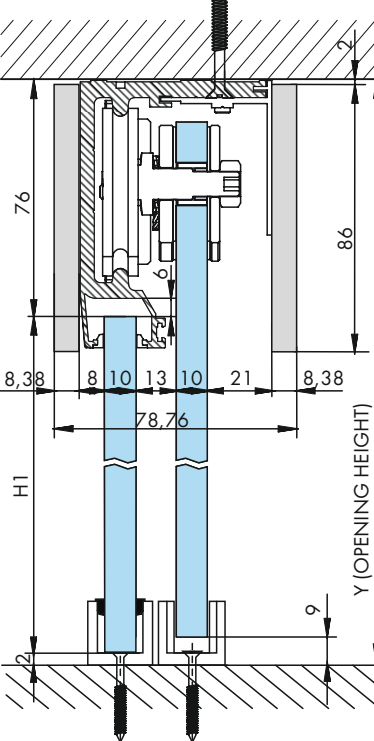
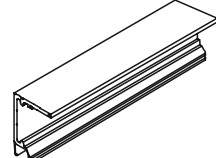

Sliding system with covered guide S-2000 on rollers

Assembly drawings System elements

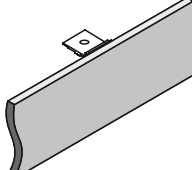
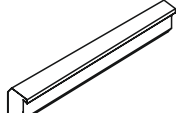
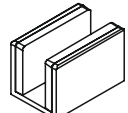
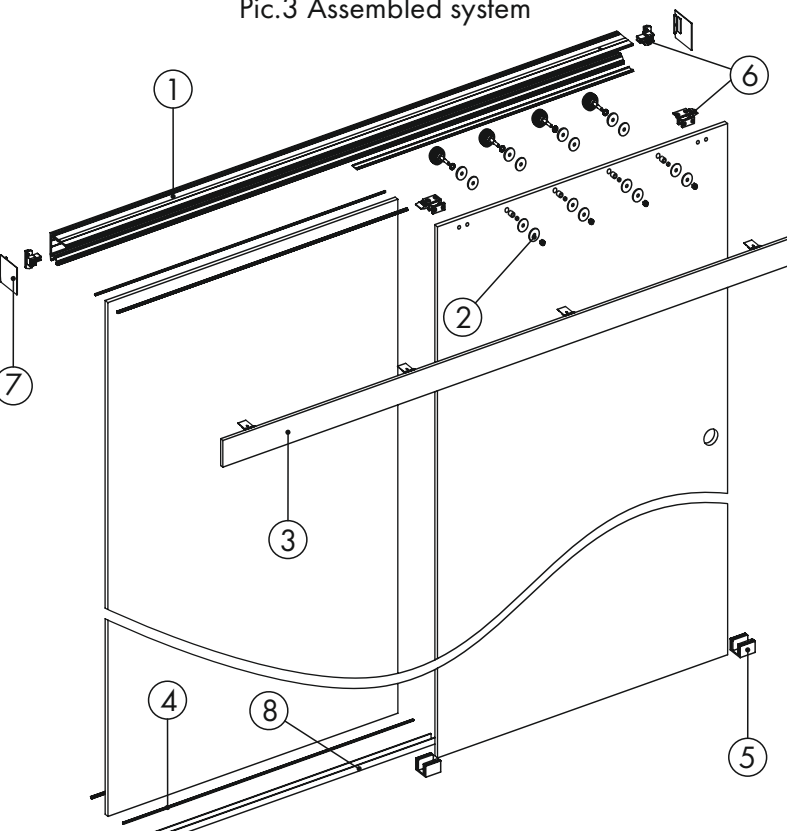
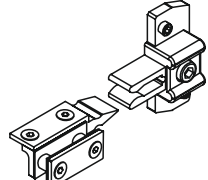
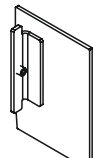
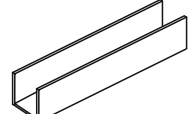
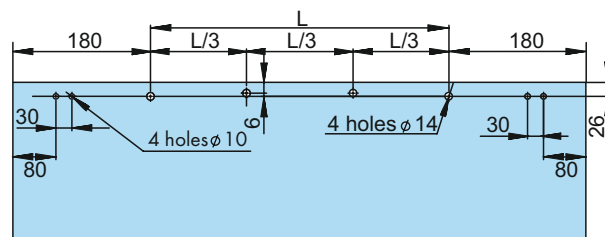
| | | |
|--|--|--|
| <p>Pic.1 Wall mounting</p>  | <p>Pic.2 Ceiling mounting</p>  | <p>1. Guide track</p>  |
| | | <p>2. Roller for door leaf fastening</p>  |
| | | <p>3. Decorative cover</p>  |
| | | <p>4. Gasket</p>  |
| | | <p>5. Floor guide for mobile leaf</p>  |
| <p>Pic.3 Assembled system</p>  | | <p>6. Set of stoppers with latches</p>  |
| | | <p>7. End cap</p>  |
| | | <p>8. Floor guide for fixed leaf</p>  |
| | | <p>Pic.4 Holes milling for panel with rollers</p>  |

Sliding system with covered guide S-2000 on rollers

Design parameters

4-panel sliding system

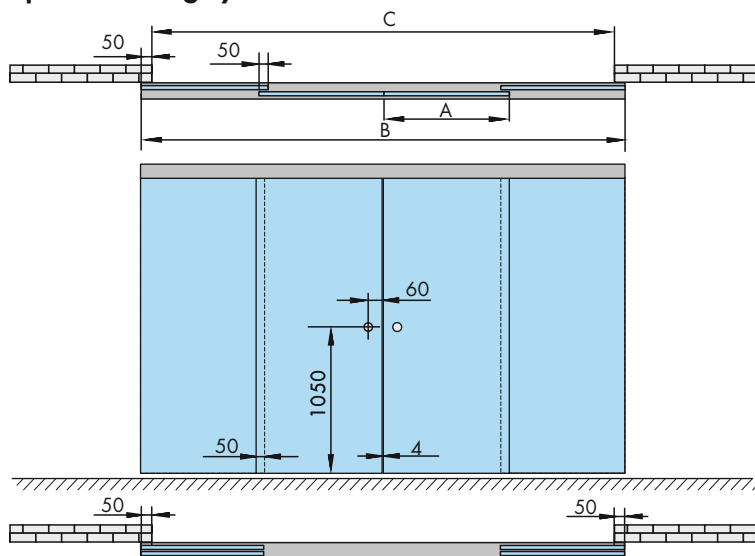

mounting on opening:

$$A = C/4 + 49$$

$$B \text{ (mounting on opening)} = C + 100$$

$$H1 = Y + 8$$

$$H2 = Y + 64$$

mounting in opening:

$$A = C/4 + 48$$

$$B \text{ (mounting in opening)} = C - 4$$

$$H1 = Y - 78$$

$$H2 = Y - 22$$

C – opening width;

A – door leaf width;

B – guide track length;

H1 – fixed door leaf height;

H2 – mobile door leaf height;

Y – opening height.

2-panel sliding system

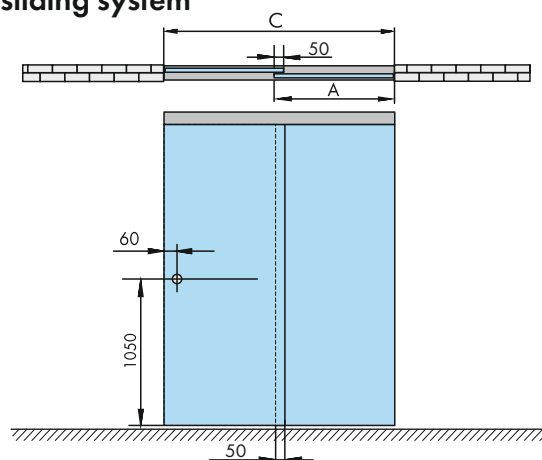

2-panel sliding system

mounting in opening:

$$A = C/2 + 23$$

$$B = C - 4$$

$$H1 = Y - 78$$

$$H2 = Y - 22$$

C – opening width;

A – door leaf width;

B – guide track length;

H1 – fixed door leaf height;

H2 – mobile door leaf height;

Y – opening height.

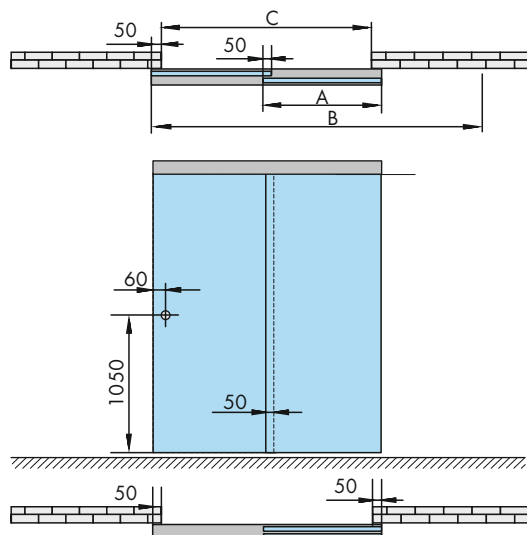

2-panel sliding system

mounting on opening:

$$A = C/2 + 75$$

$$B = 1,5C + 75$$

$$H1 = Y + 8$$

$$H2 = Y + 64$$

C – opening width;

A – door leaf width;

B – guide track length;

H1 – fixed door leaf height;

H2 – mobile door leaf height;

Y – opening height.

Sliding system with covered guide S-2000 on clamps

Assembly drawings System elements

Pic. 1 Wall mounting

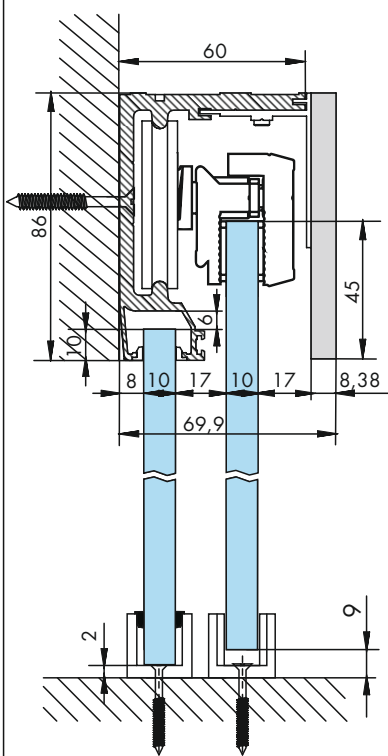

Pic. 2 Ceiling mounting

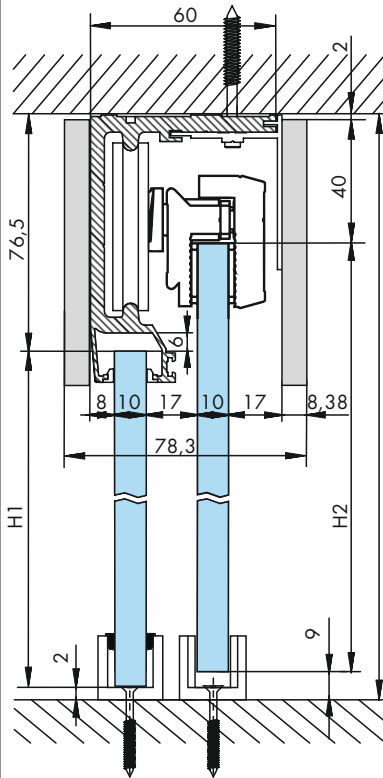

1. Guide track

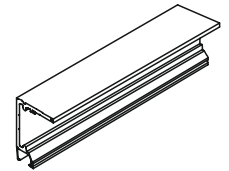

2. Clamping profile with fastener

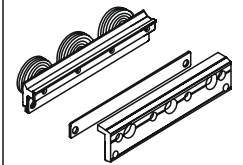

3. Damper

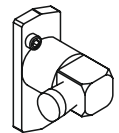

4. Decorative cover

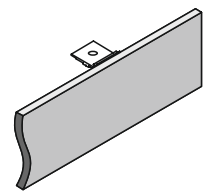

Pic. 3 Assembled system

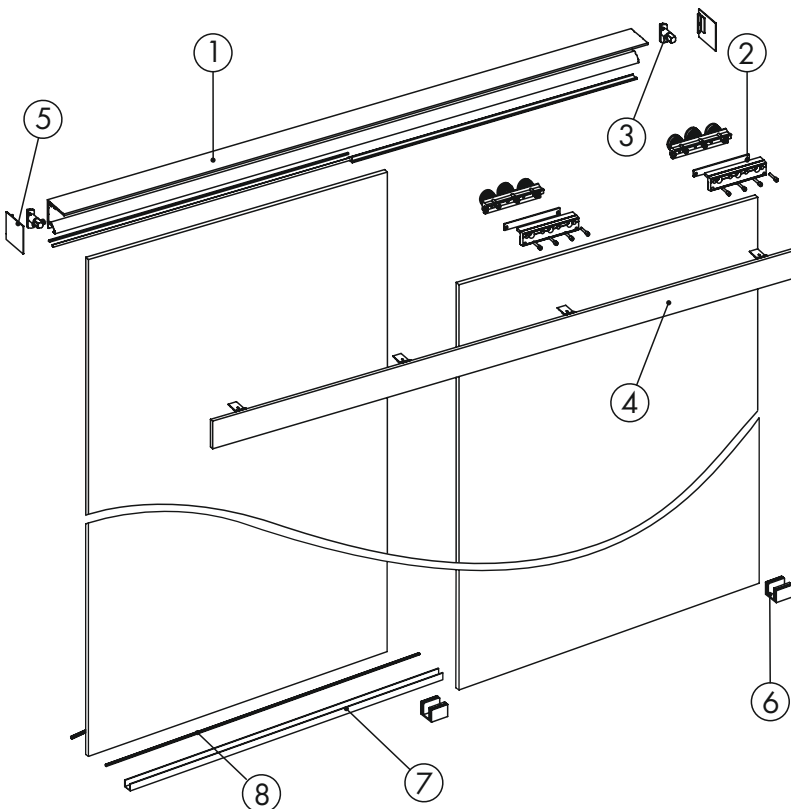

5. End cap

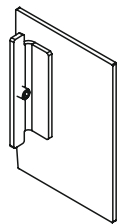

6. Floor guide for mobile leaf

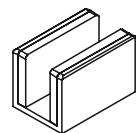

7. Floor guide for fixed leaf

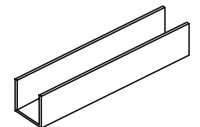

8. Gasket

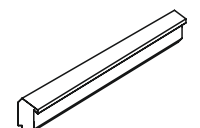

Sliding system with covered guide S-2000 on clamps

Design parameters

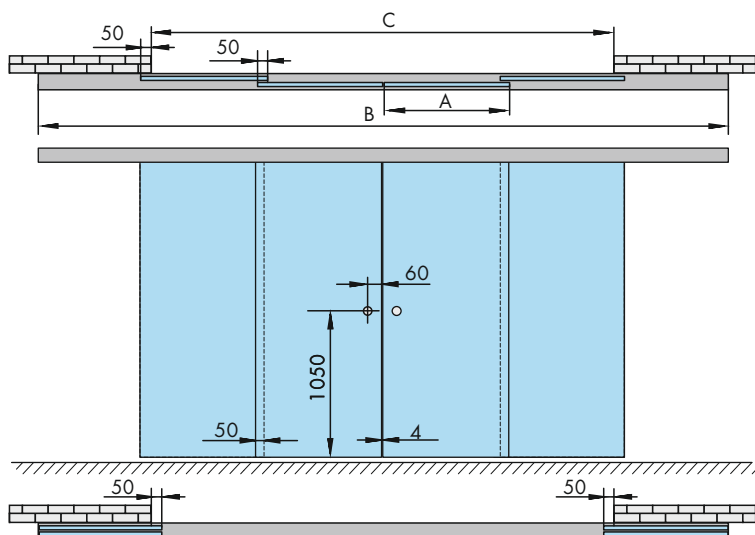

4-panel sliding system mounting on opening:

$$A = (C - 4) / 4 + 50$$

$$B = C + 2A - 200$$

$$H1 = Y + 7,5$$

$$H2 = Y + 37$$

C – opening width;
 A – door leaf width;
 B – guide track length;
 H1 – fixed door leaf height;
 H2 – mobile door leaf height;
 Y – opening height.

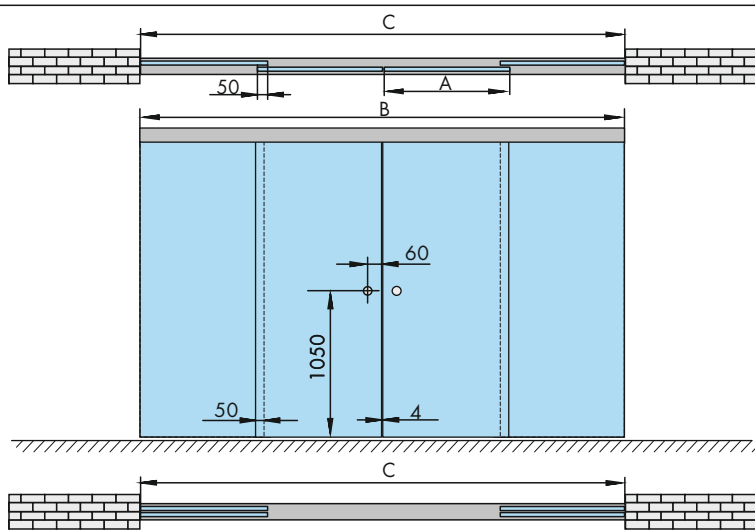

4-panel sliding system mounting in opening:

$$A = (C - 4) / 4 + 25$$

$$B = C - 4$$

$$H1 = Y - 78,5$$

$$H2 = Y - 49$$

C – opening width;
 A – door leaf width;
 B – guide track length;
 H1 – fixed door leaf height;
 H2 – mobile door leaf height;
 Y – opening height.

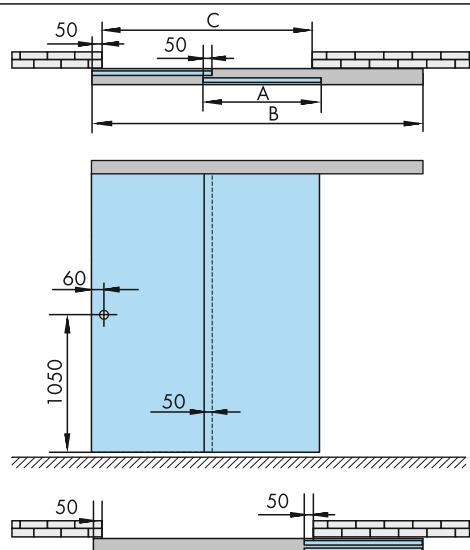

2-panel sliding system mounting on opening:

$$A = C - 2 / 2 + 50$$

$$B = 1,5C - 3$$

$$H1 = Y + 7,5$$

$$H2 = Y + 37$$

2-panel sliding system mounting in opening:

$$A = C / 2 + 25$$

$$B = C - 4$$

$$H1 = Y - 78,5$$

$$H2 = Y - 49$$

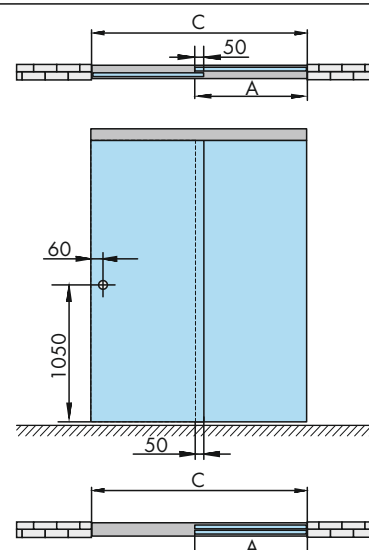

Sliding system with covered guide S-2000 with panel shift

Doors opening diagram

1-panel system:

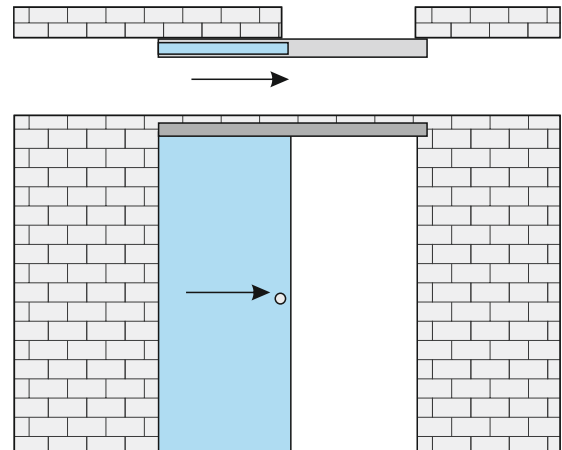
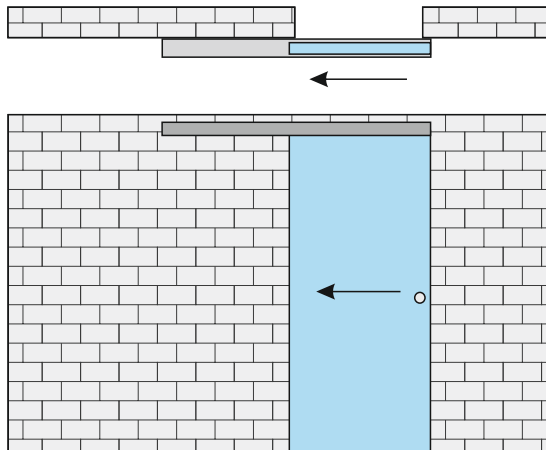

2-panel system:

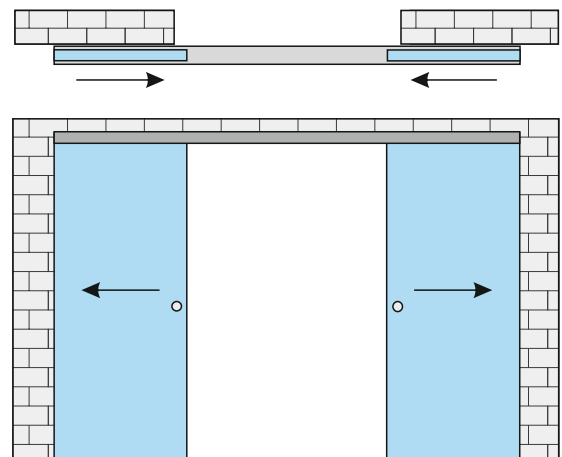
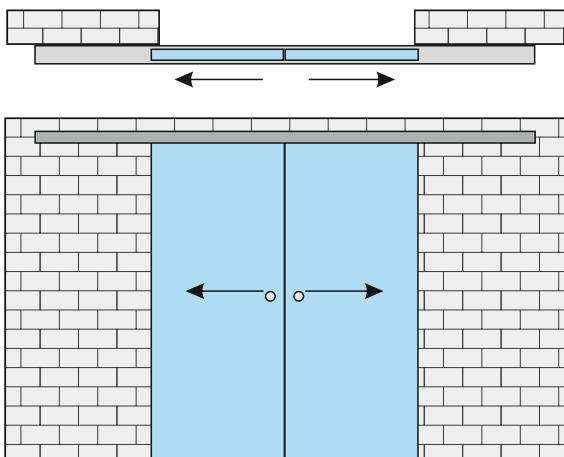

Leaf fastening elements disposition

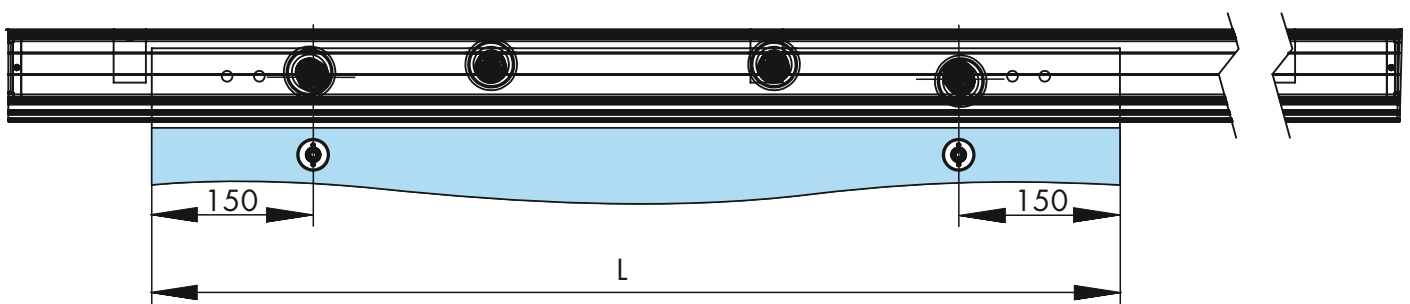

Sliding system with covered guide S-2000 with panel shift

Assembly drawings System elements

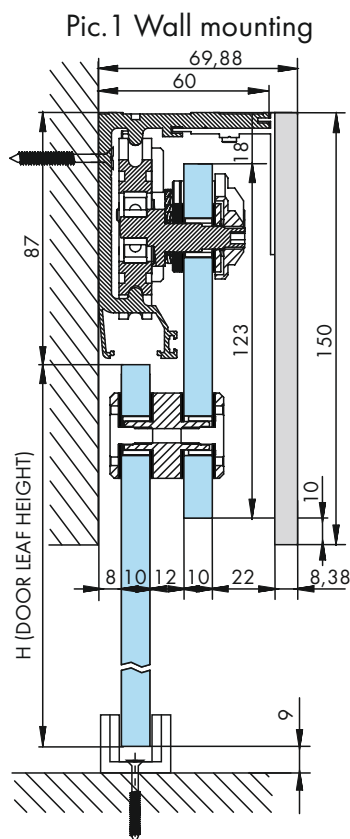

1. Guide track

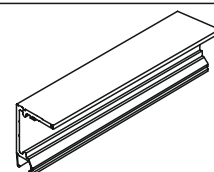

2. Decorative cover

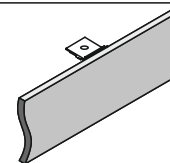

3. Set of stoppers with latches

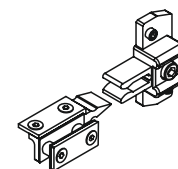

4. End cap

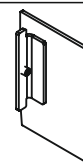

5. Roller for supporting glass panel fastening



Pic.2 Assembled system

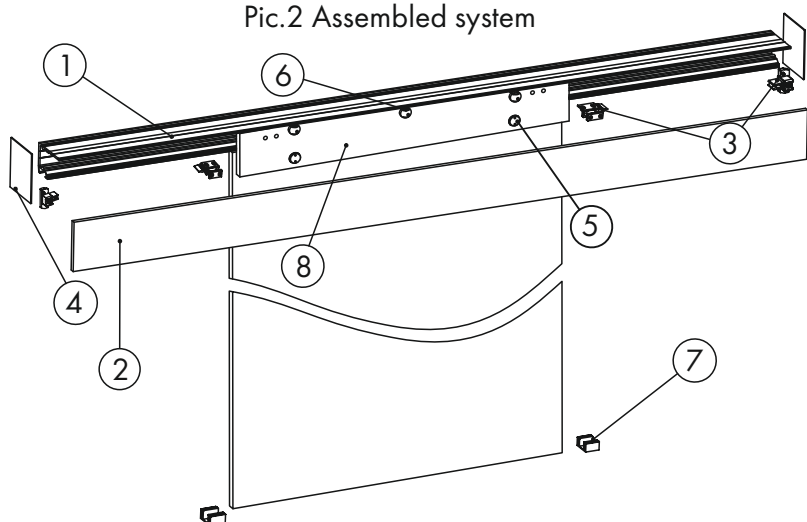

6. Roller for door leaf fastening



7. Floor guide for mobile leaf

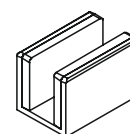

8. Supporting glass panel

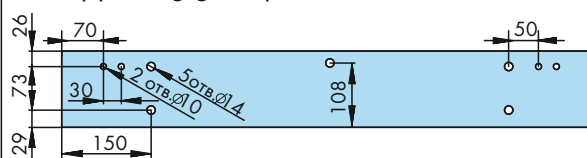

Pic.3 Leaf drillings layout

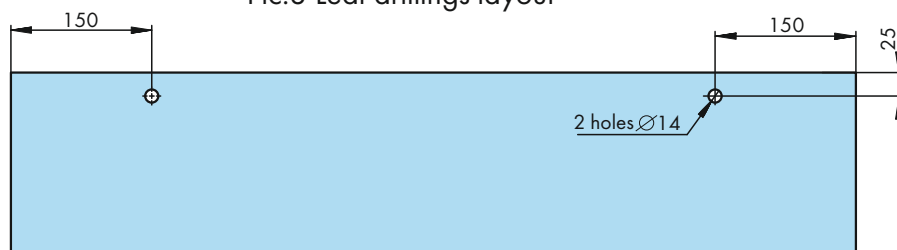

Sliding system with covered guide S-2000 with panel shift

Design parameters

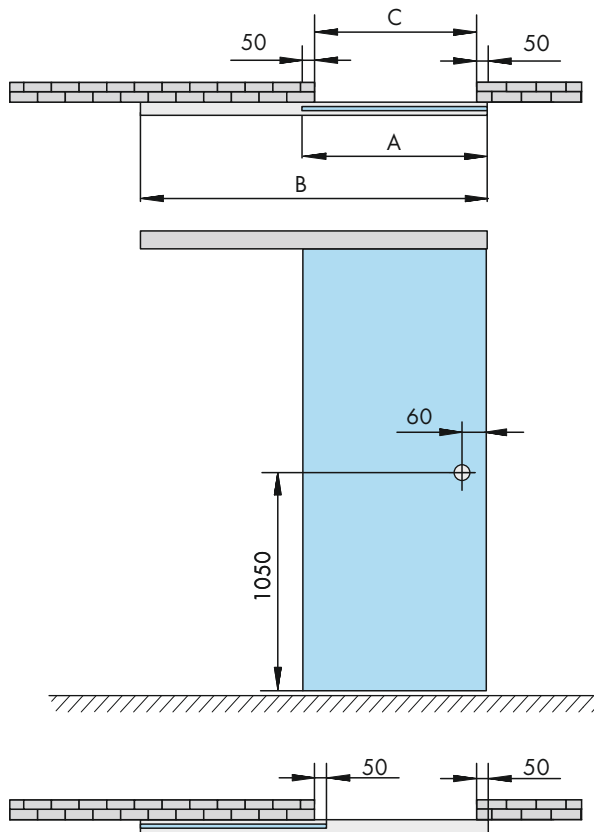

1-panel sliding system

$$A = C + 100$$

$$B = 2C + 100$$

$$H \text{ (wall mounting)} = Y + 54$$

$$H \text{ (ceiling mounting)} = Y - 96$$

C – opening width; A – door leaf width;
B – guide track length;
H – door leaf height; Y – opening height

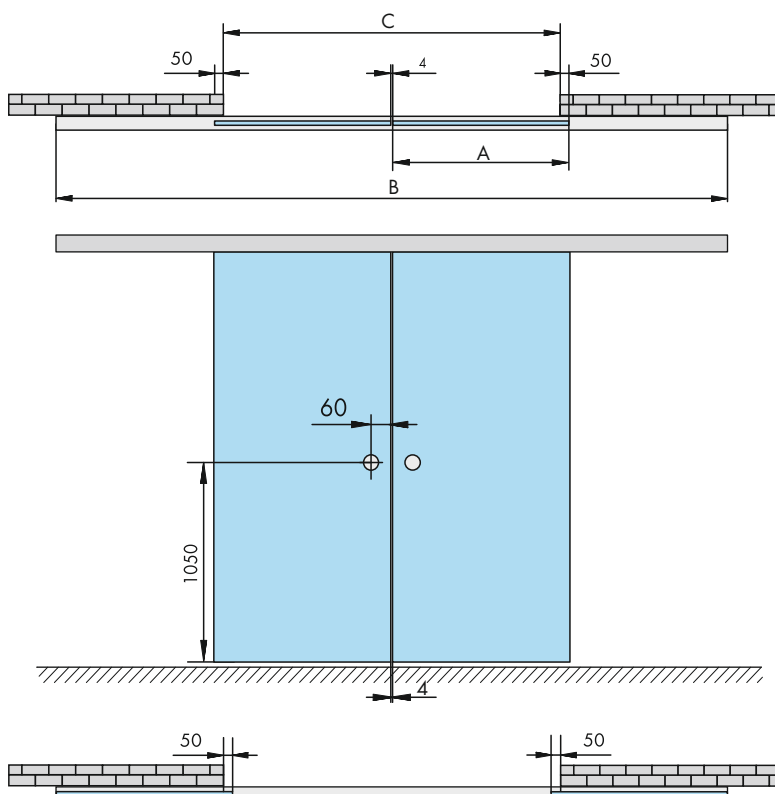

2-panel sliding system

$$A = (C - 4) / 2 + 50$$

$$B = 2C - 4$$

$$H \text{ (wall mounting)} = Y + 54$$

$$H \text{ (ceiling mounting)} = Y - 96$$

C – opening width; A – door leaf width;
B – guide track length;
H – door leaf height; Y – opening height

Sliding system with covered guide S-4000

Doors opening diagram

Mounting on opening:

a) three panels:

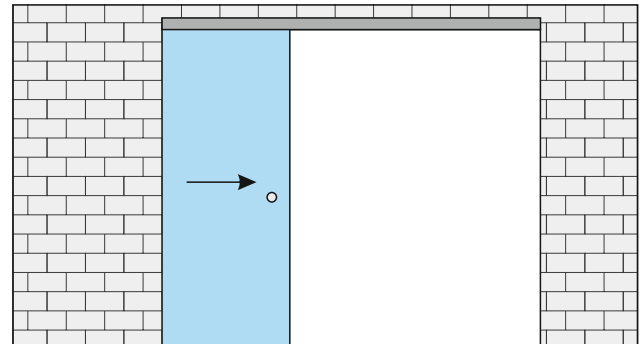
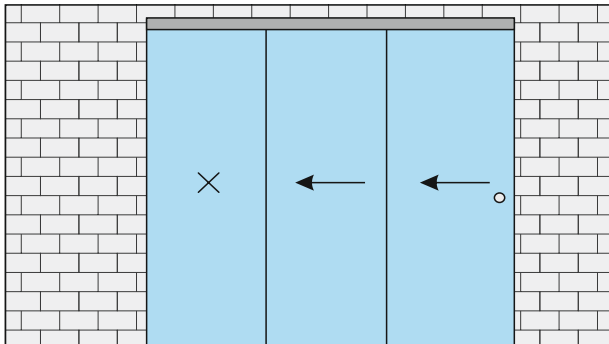

b) six panels:

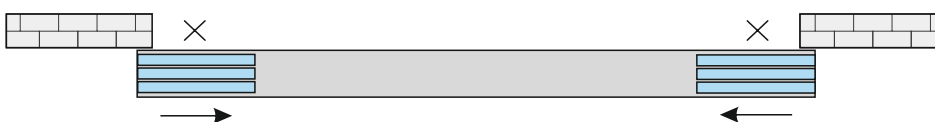
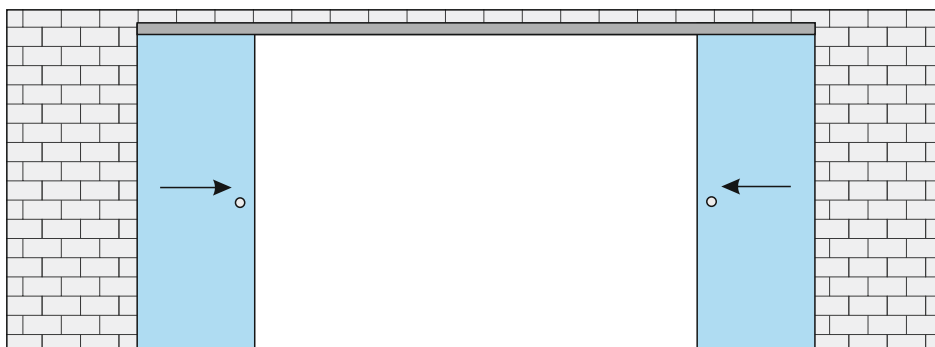
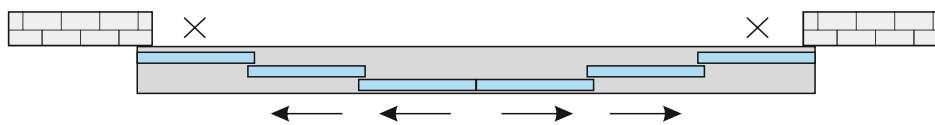
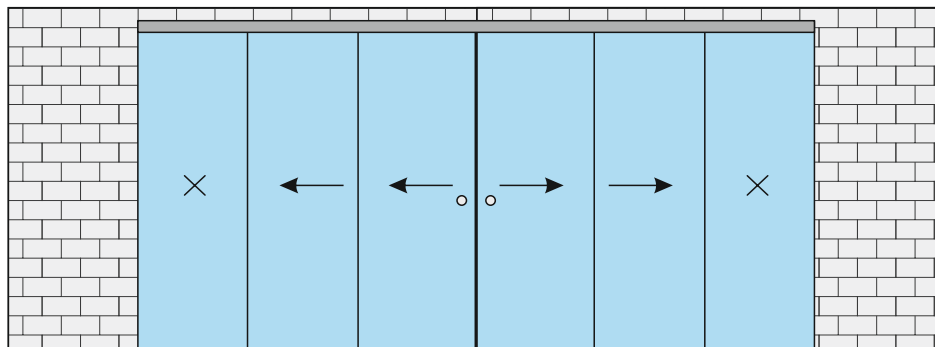

Sliding system with covered guide S-4000

Doors opening diagram

Mounting in opening:

a) three panels:

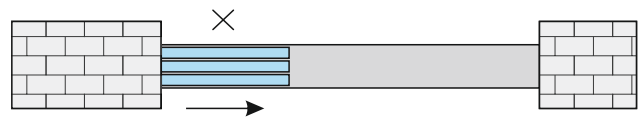
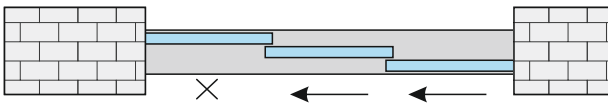
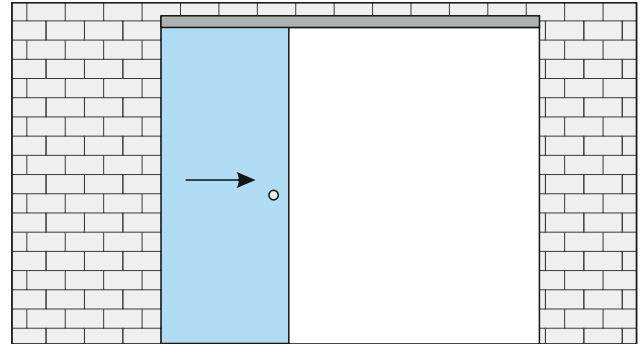
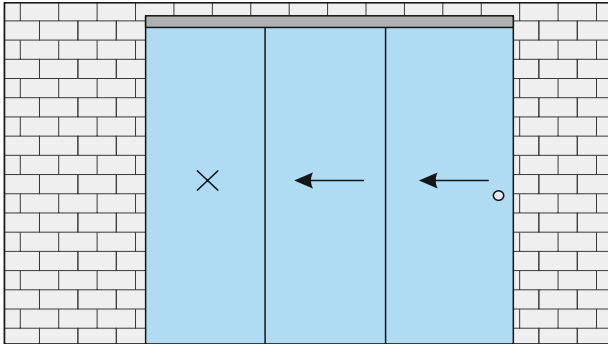

b) six panels:

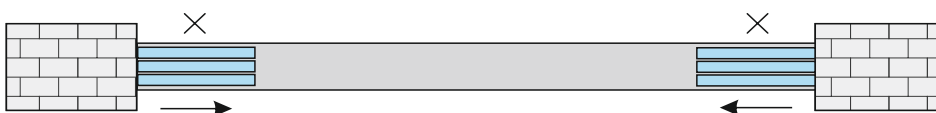
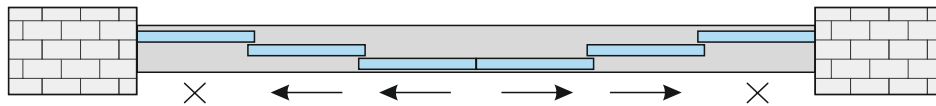
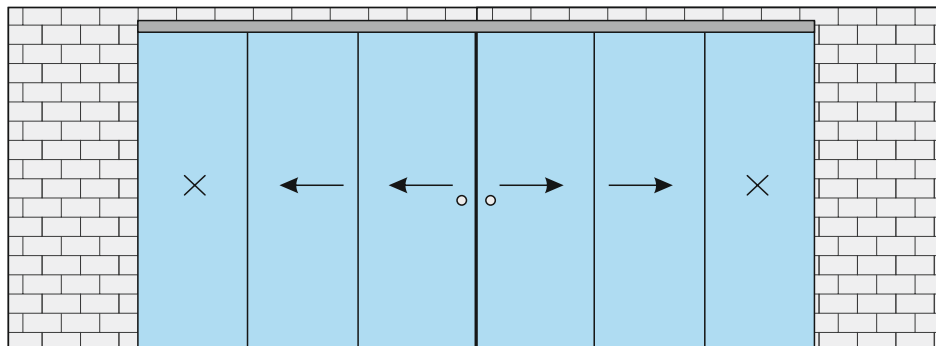

Sliding system with covered guide S-4000

Assembly drawings System elements

Pic.1 Layout of fasteners disposition

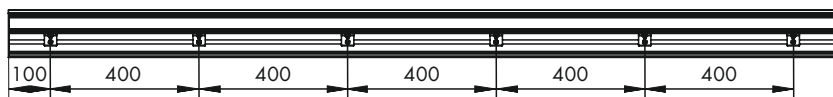

Pic.2 Wall mounting

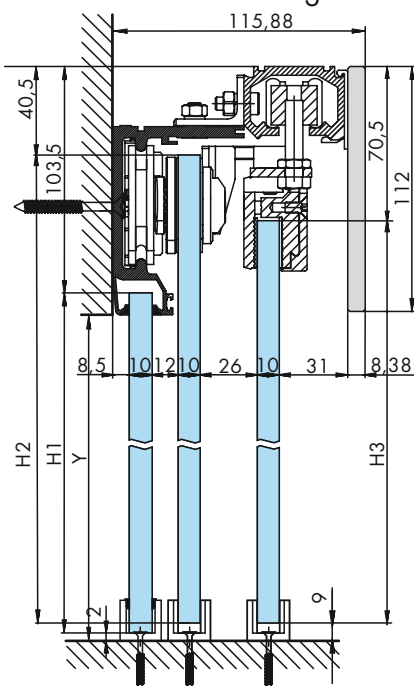

Pic.3 Ceiling mounting

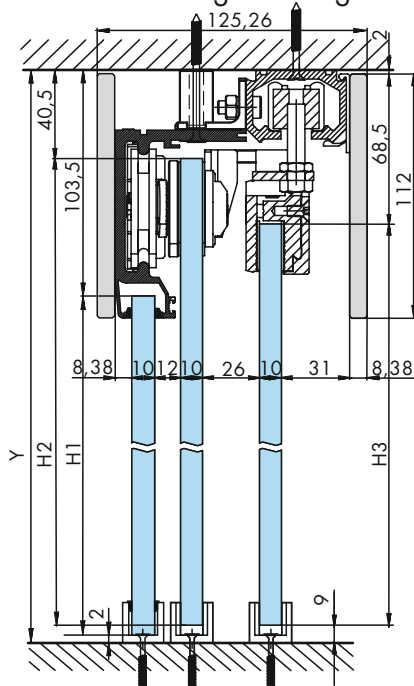

Pic.4 Assembled system

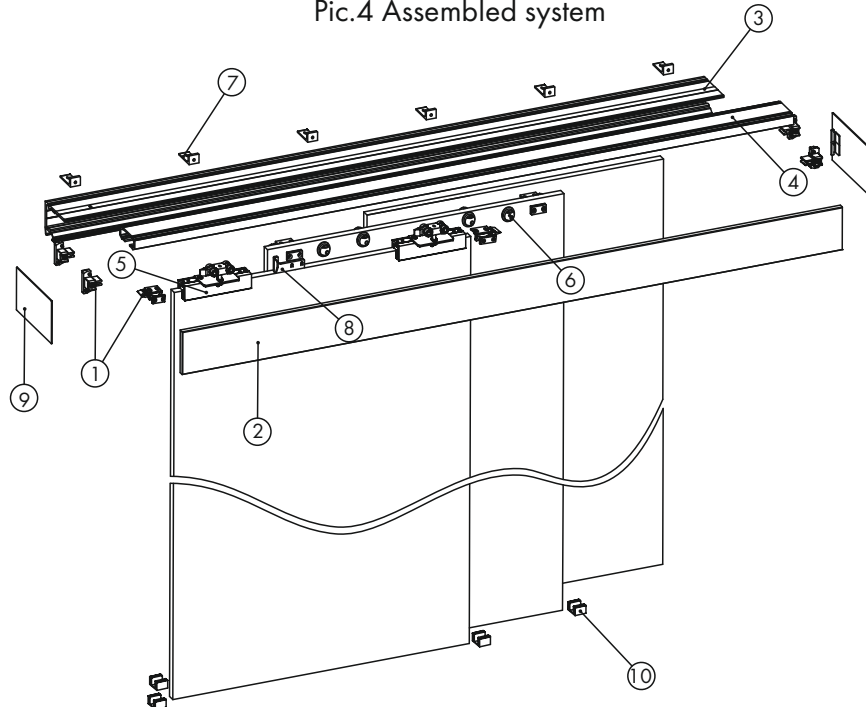

1. Set of stoppers with latches

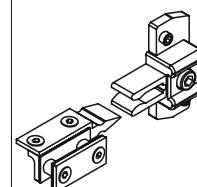

2. Decorative cover

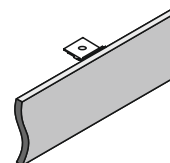

3. Guide track for leaf 1,2

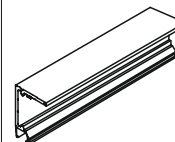

4. Guide track for leaf 3

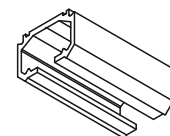

5. Carriage for leaf 3 fastening

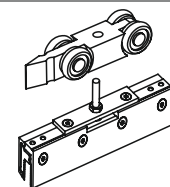

6. Roller for leaf 2 fastening



7. Fastening

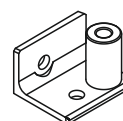

8. Telescopic holder

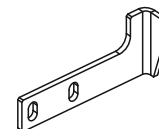

9. End cap

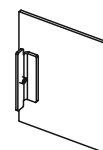

10. Floor guide for mobile leaf

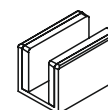

Sliding system with covered guide S-4000

Design parameters

3-panels sliding system

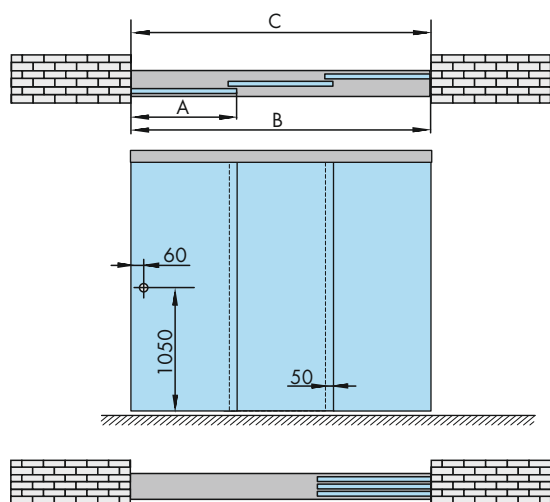

mounting in opening:

$$\begin{aligned} A &= C/3 + 32 \\ B &= C - 4 \\ H1 &= Y - 105,5 \\ H2 &= Y - 49,5 \\ H3 &= Y - 79,5 \end{aligned}$$

mounting on opening:

$$\begin{aligned} A &= C/3 + 50 \\ B &= 4A - 200 \\ H1 &= Y + 6,5 \\ H2 &= Y + 62,5 \\ H3 &= Y + 32,5 \end{aligned}$$

C – opening width;
A – door leaf width;
B – guide track length;
H1 – fixed door leaf height;
H2, H3 – mobile door leaf height;
Y – opening height.

6-panel sliding system

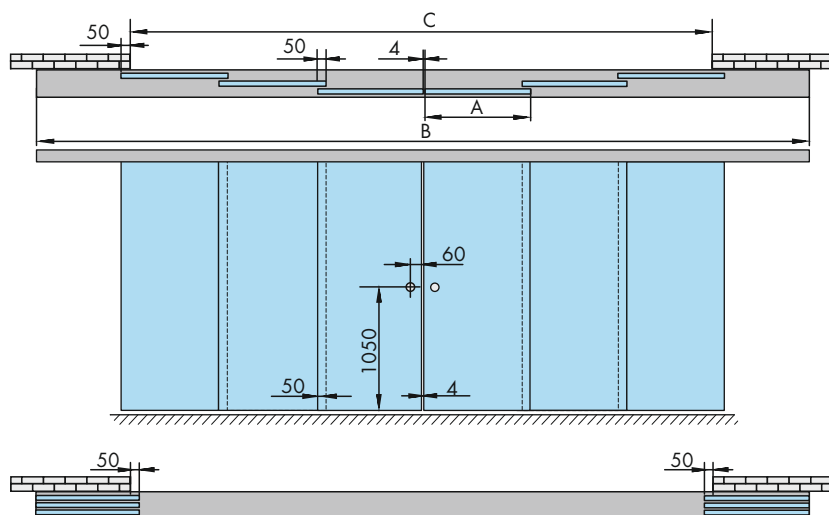

mounting

in opening:

$$\begin{aligned} A &= (C - 4) / 6 + 50 \\ B &= C + 2A - 200 \\ H1 &= Y + 6,5 \\ H2 &= Y + 62,5 \\ H3 &= Y + 32,5 \end{aligned}$$

on opening:

$$\begin{aligned} A &= C/6 + 32 \\ B &= C - 4 \\ H1 &= Y - 105,5 \\ H2 &= Y - 49,5 \\ H3 &= Y - 79,5 \end{aligned}$$

C – opening width;
A – door leaf width;
B – guide track length;
H1 – fixed door leaf height;
H2, H3 – mobile door leaf height;
Y – opening height.

Leaf 1 drillings layout

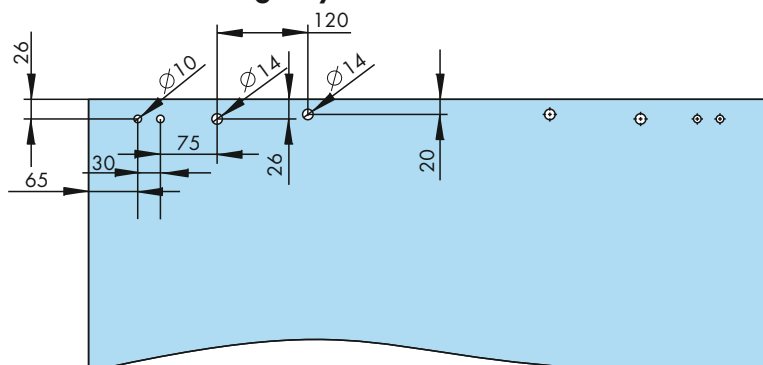

Sliding system with covered guide S-4100

Doors opening diagram

Mounting on opening:

a) 4-panels:

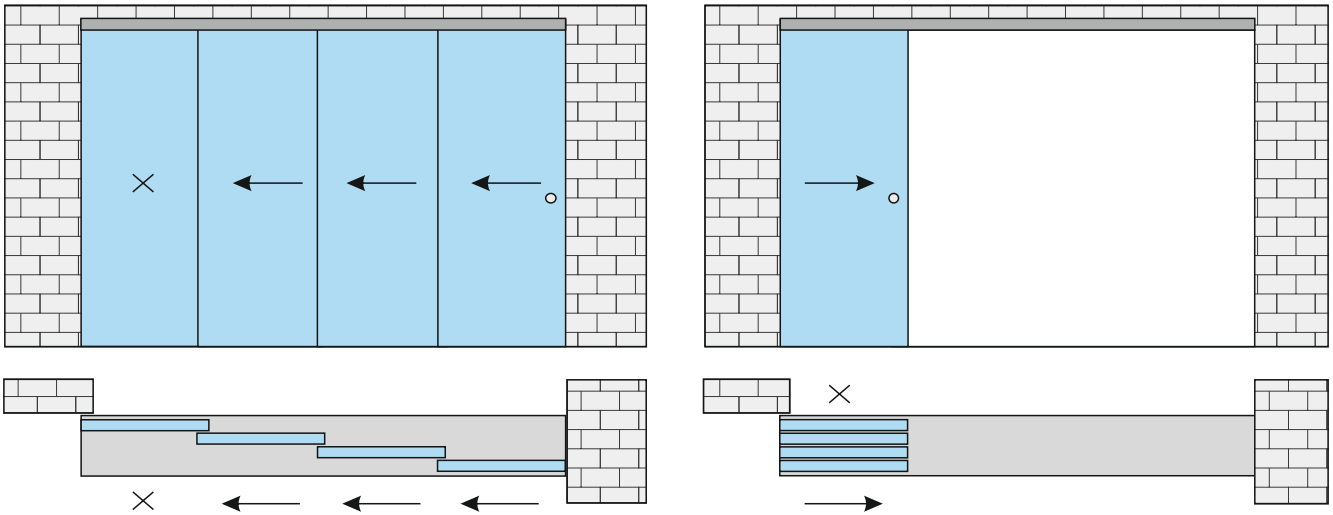

b) 8-panels:

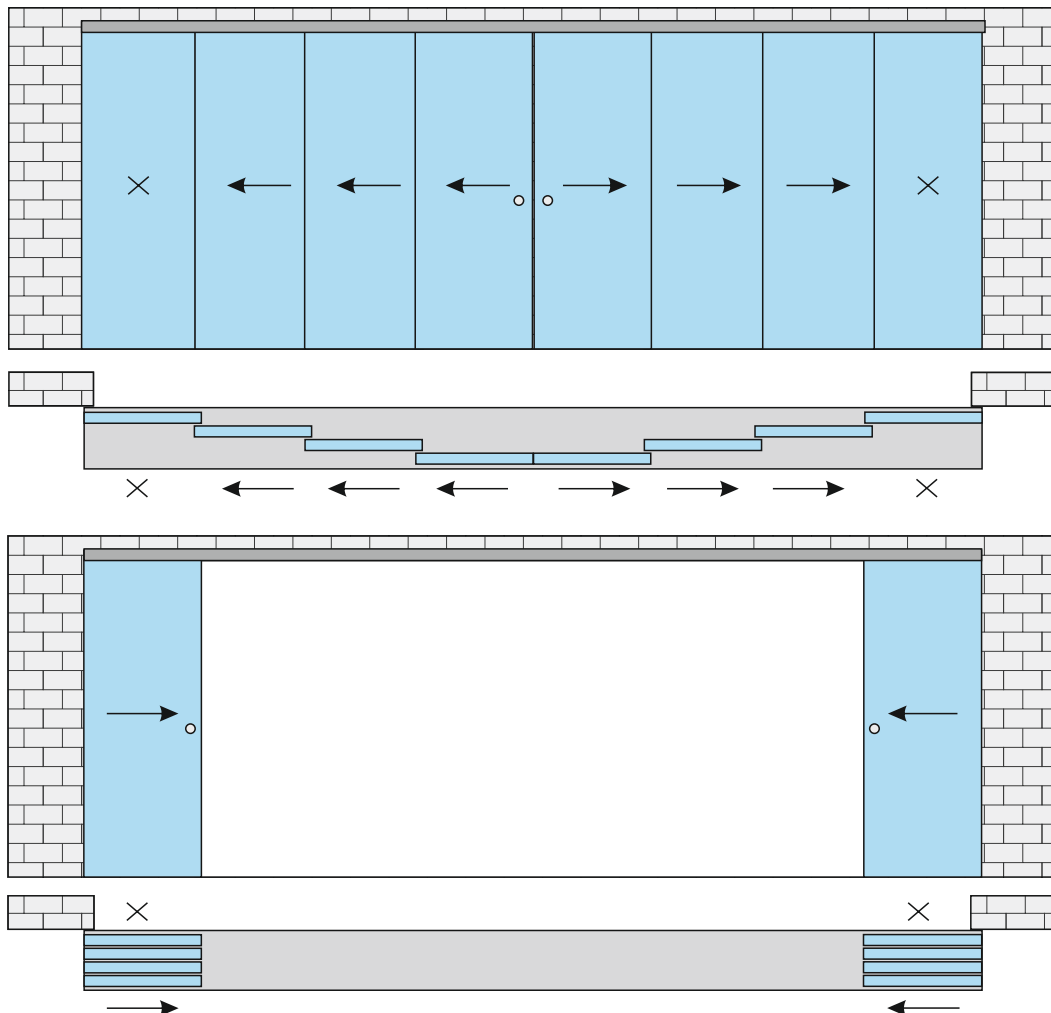

Sliding system with covered guide S-4100

Doors opening diagram

Mounting in opening:

a) 4-panels:

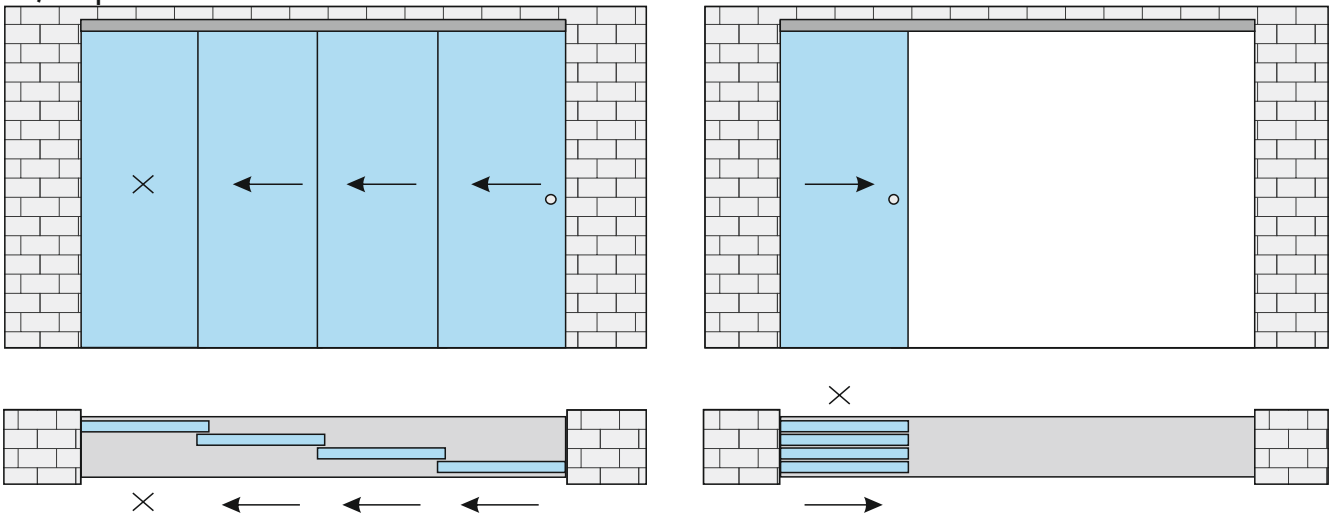

b) 8-panels:

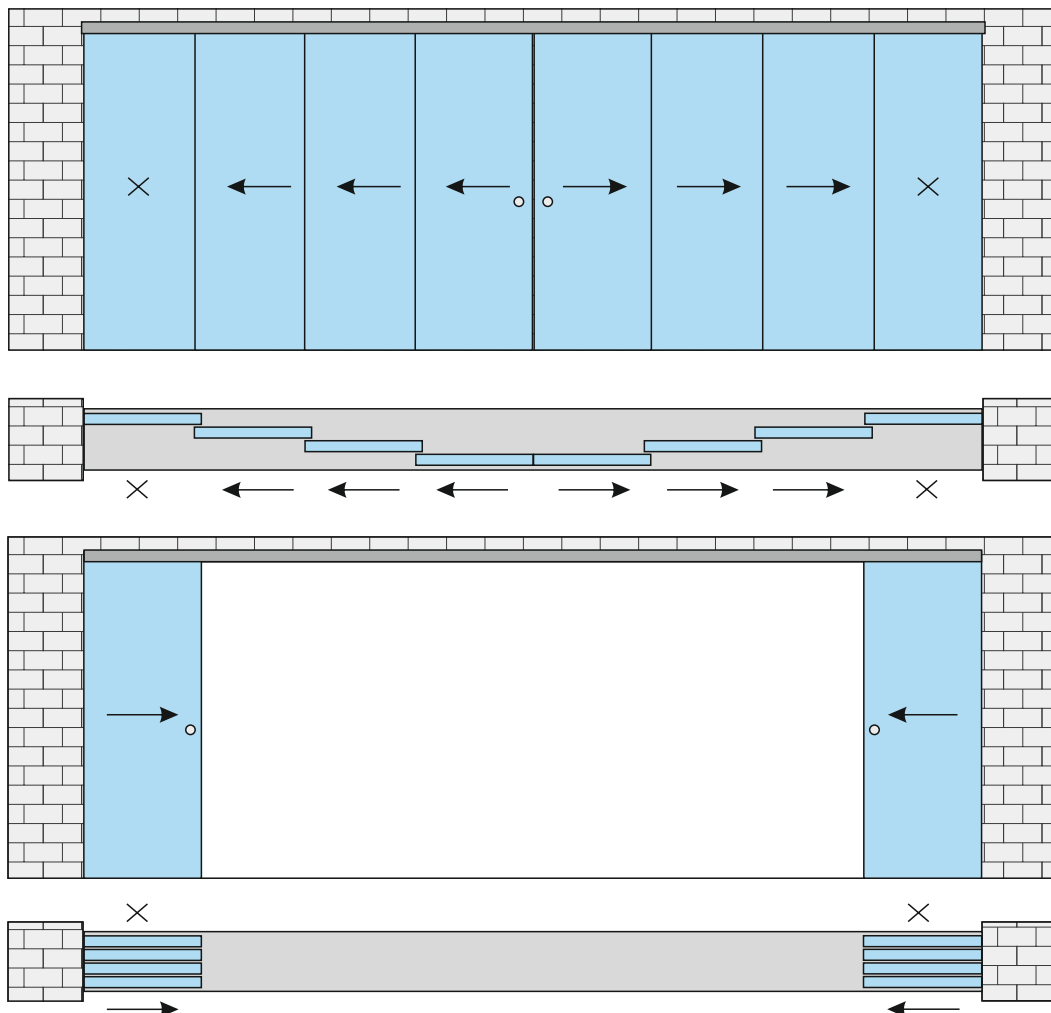

Sliding system with covered guide S-4100

Assembly drawings Layout of fasteners

Pic.1 Ceiling mounting

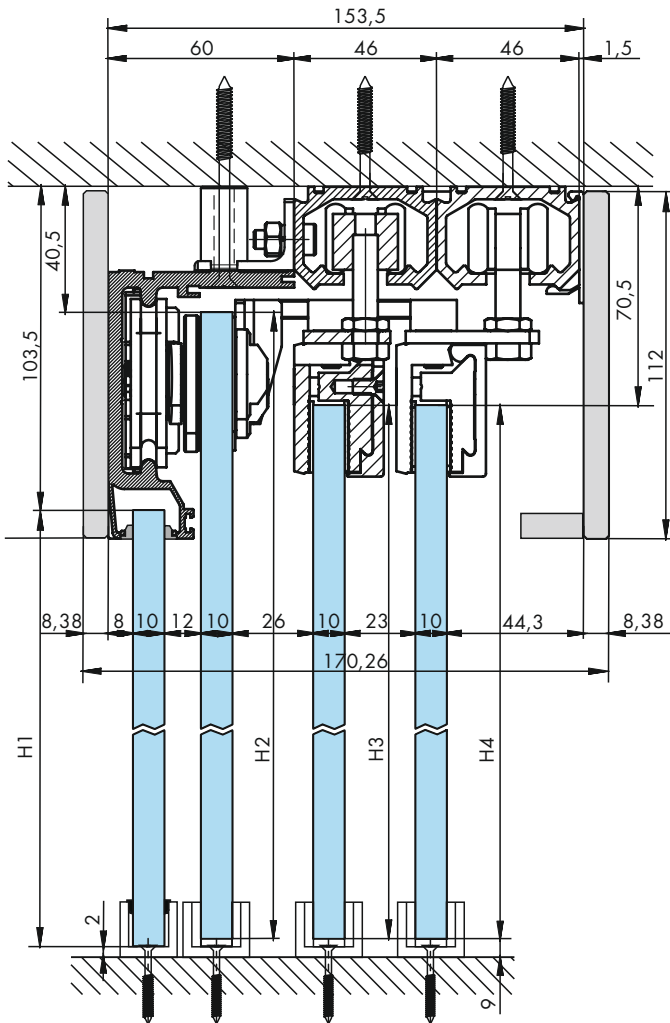

Pic.2 Wall mounting

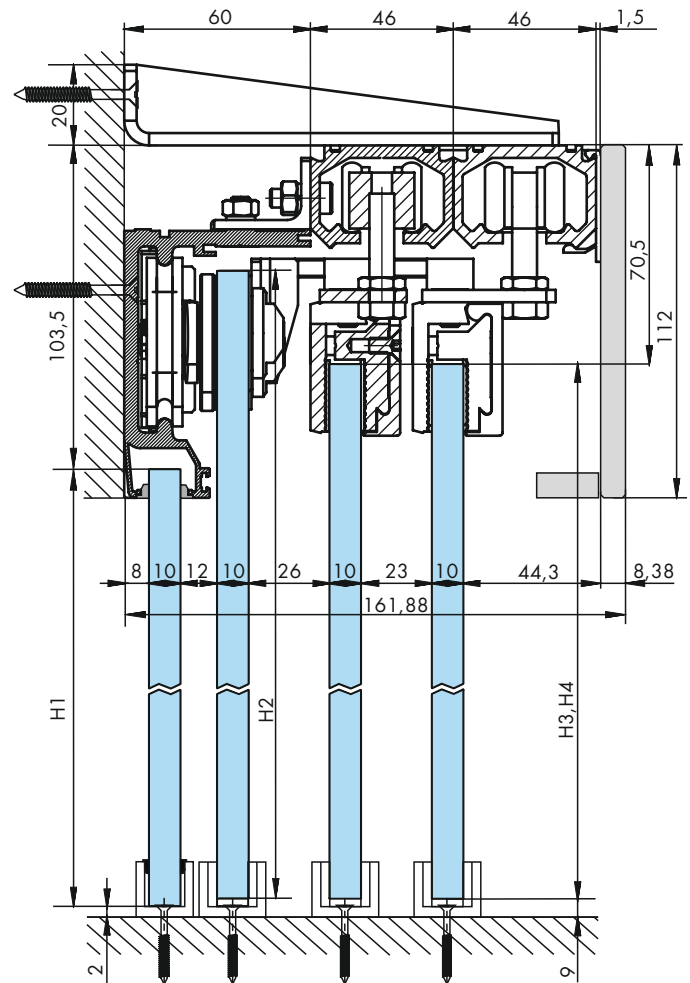

Pic.3 Layout of mounting fasteners

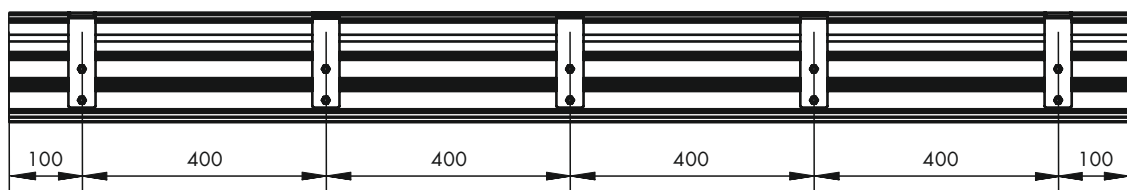

| Sliding system with covered guide S-4100 | | System elements | | | |
|--|--|--|--|--------------------------------|--|
| <p>Pic.4 Assembled system</p> | | 1. Guide track for leaf 2 | | | |
| | | 2. Guide track for leaves 3-4 | | | |
| | | 3. Set of stoppers with latches | | | |
| | | 4. Decorative cover | | | |
| | | 5. Fastening angle (for wall mounting version) | | | |
| | | 6. Ceiling fastener | | | |
| | | 11. Floor guide for fixed leaf | | 7. Roller for leaf 2 fastening | |
| | | 12. Floor guide for mobile leaf | | 8. Telescopic holder | |
| | | 13. Gasket | | 9. Side support | |
| | | 14. End cap | | 10. Carriage with rollers | |

Sliding system with covered guide S-4100

Design parameters

4-panel sliding system

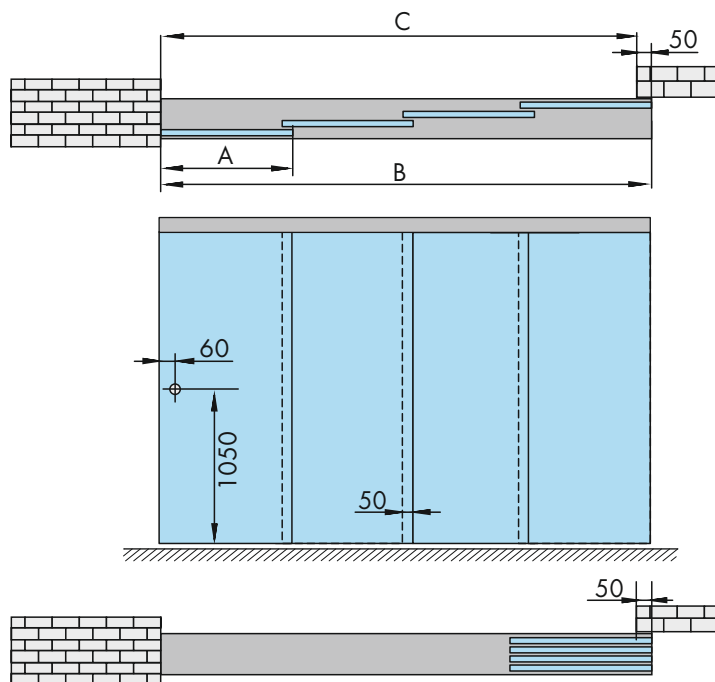

mounting in opening

$$B = C + 48$$

$$A = C/4 + 49,5$$

$$H1 = Y + 8$$

$$H2 = Y + 64$$

$$H3, H4 = Y + 52$$

mounting on opening

$$B = C - 4$$

$$A = C/4 + 36,5$$

$$H1 = Y - 105,5$$

$$H2 = Y - 49,5$$

$$H3, H4 = Y - 79,5$$

C – opening width;
 A – door leaf width;
 B – guide track length;
 H1 – fixed leaf height;
 H2, H3, H4 – mobile leaves height;
 Y – opening height.

8-panel sliding system

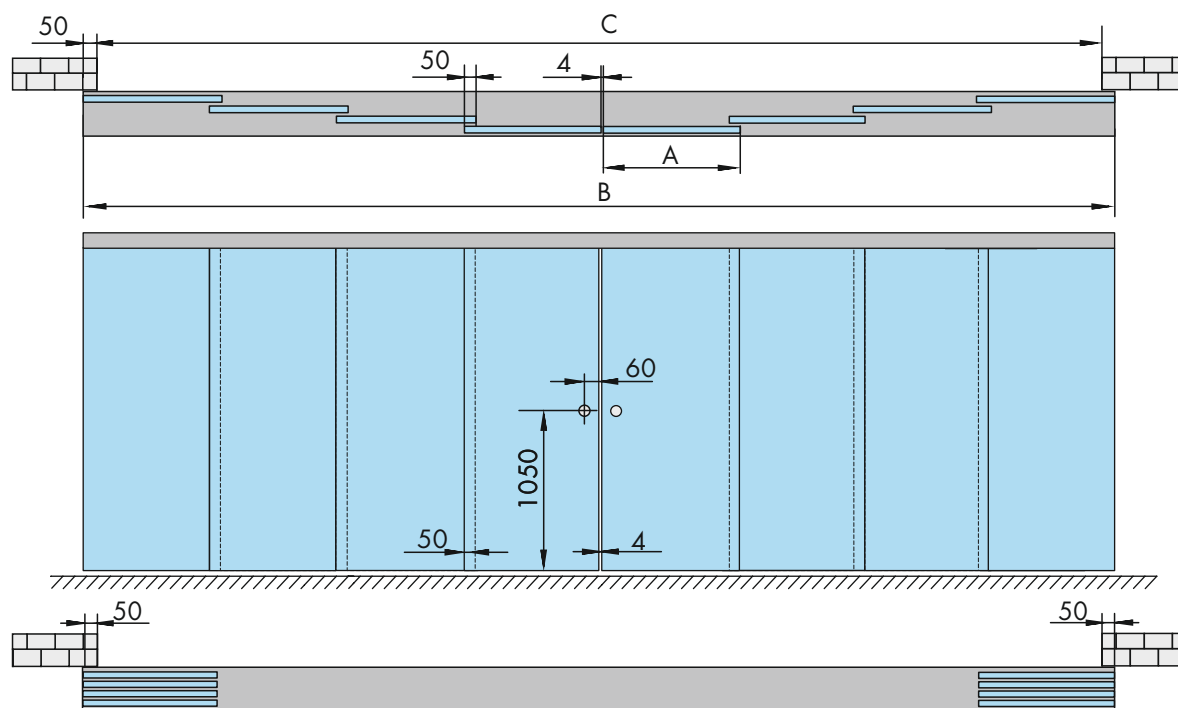

Mounting on opening

$$A = C/8 + 49,5$$

$$B = C + 100$$

Mounting in opening

$$A = C/8 + 36,5$$

$$B = C - 4$$

C – opening width; A – door leaf width;
 B – guide track length;
 Y – opening height

Sliding roller system with covered guide S-500

Doors opening diagram

1-panel system:

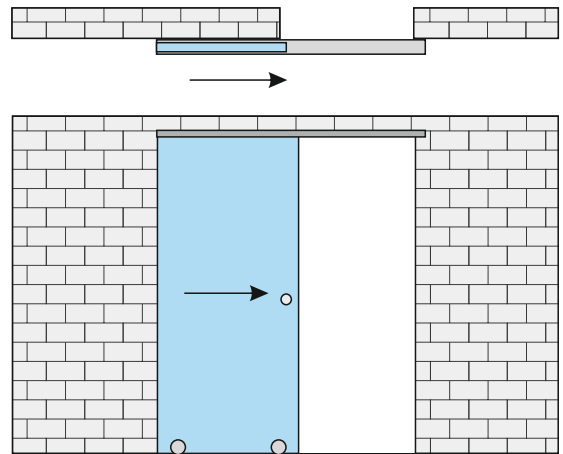
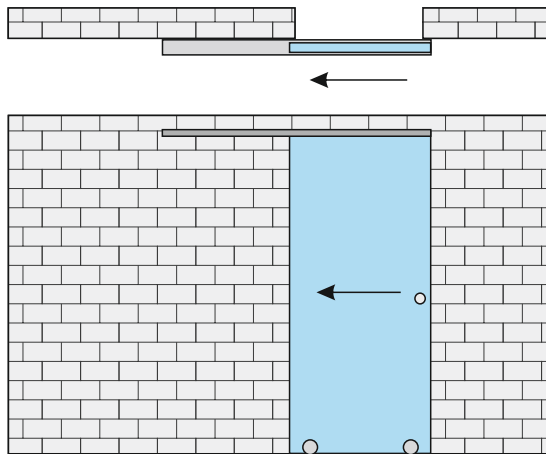

2-panel system:

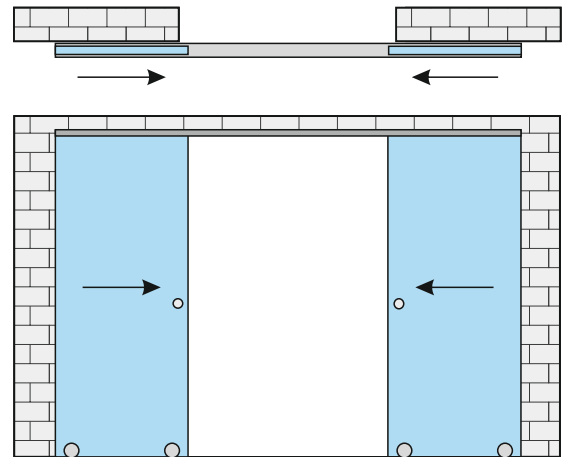
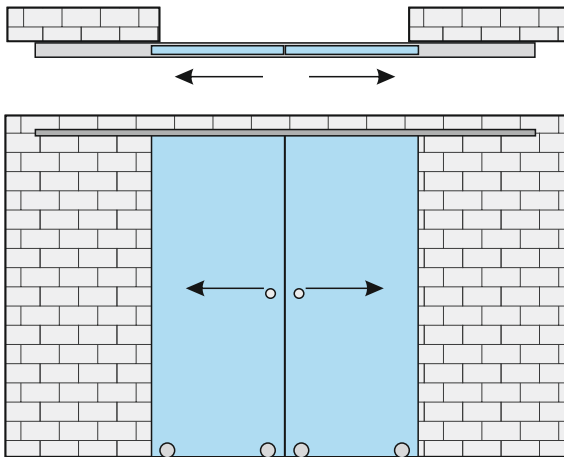

Layout of mounting fasteners

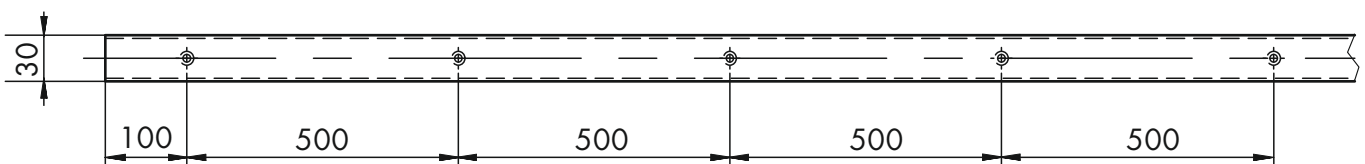

Sliding roller system with covered guide S-500

Assembly drawings

Assembled system

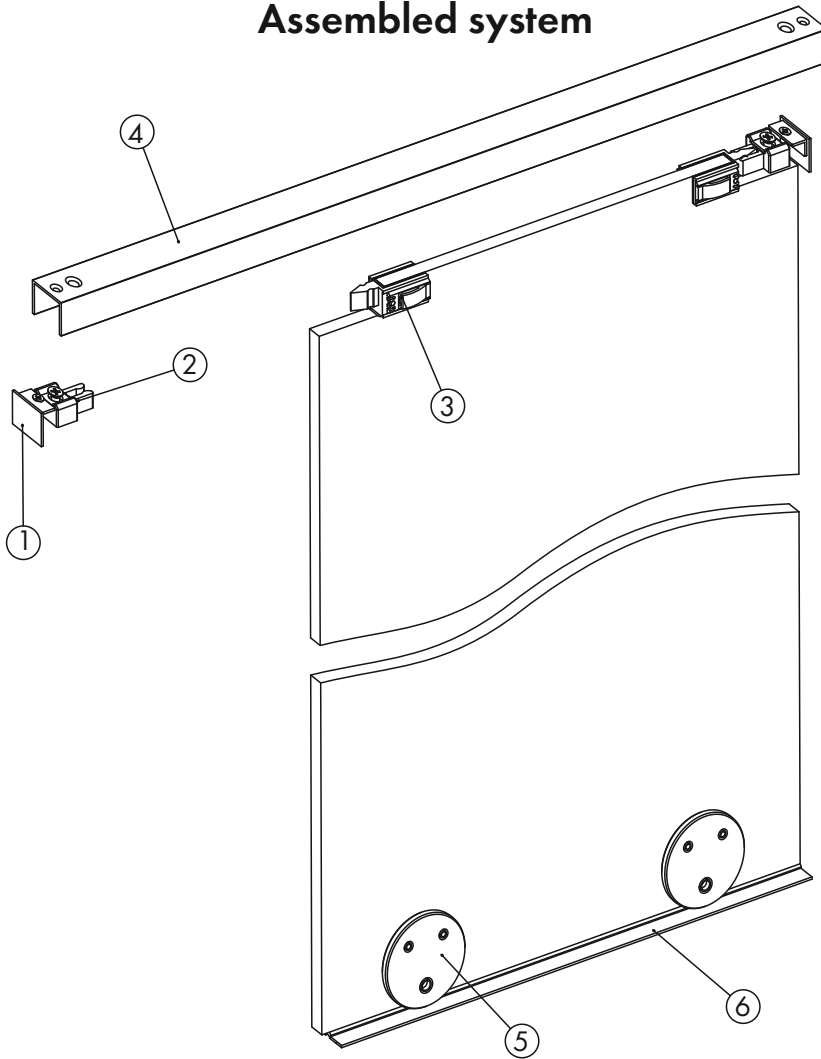

1 – End cap; 2 – side support; 3- holder;
4 – guide track; 5 – floor roller; 6 – floor guide

Wall mounting

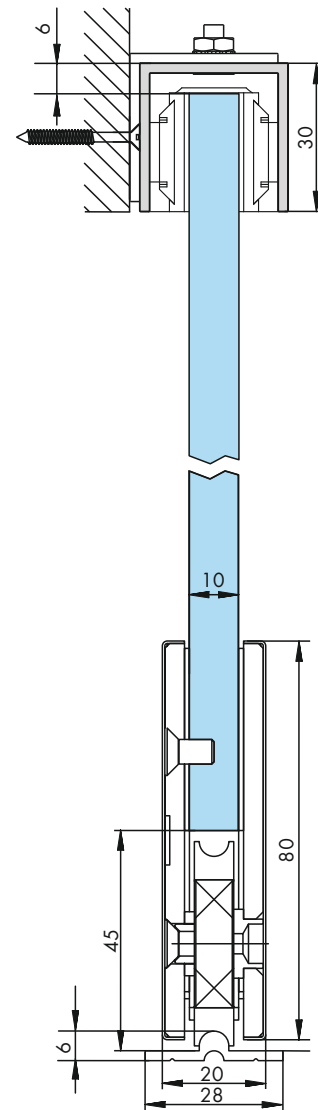

Floor roller

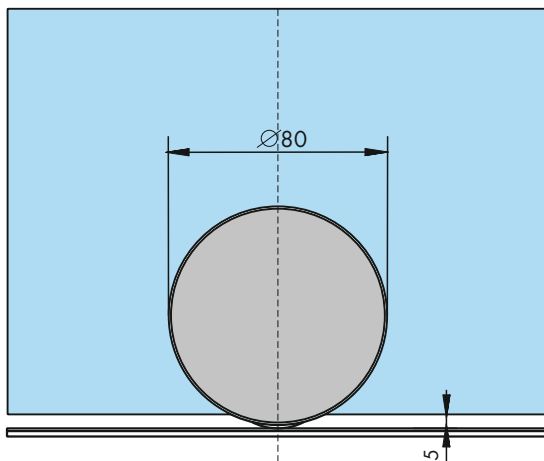

stainless steel



painting graphite, grey

Guide track

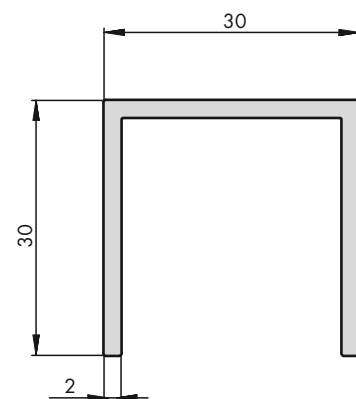

Sliding roller system with covered guide S-500

Leaf millings layout

Milling for guide track

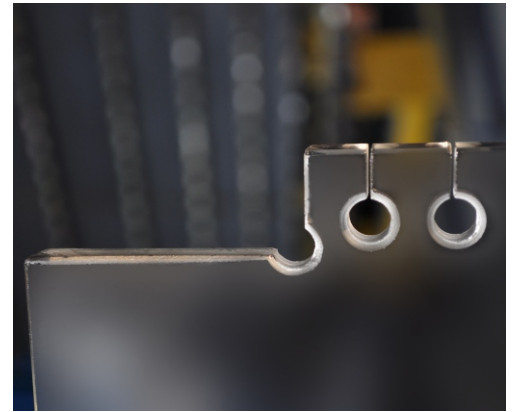
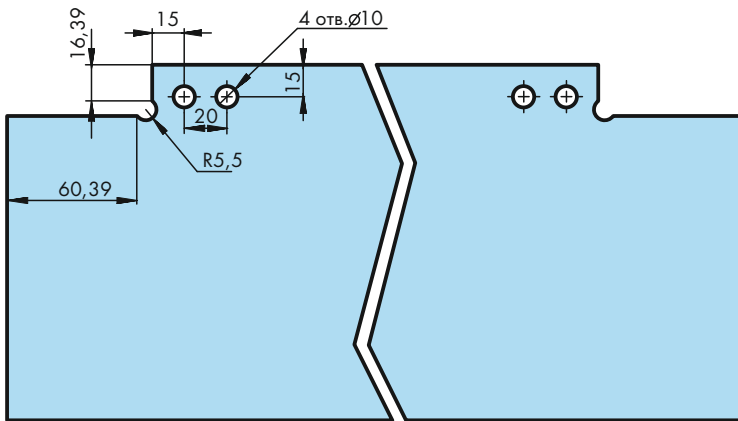

Milling for floor roller

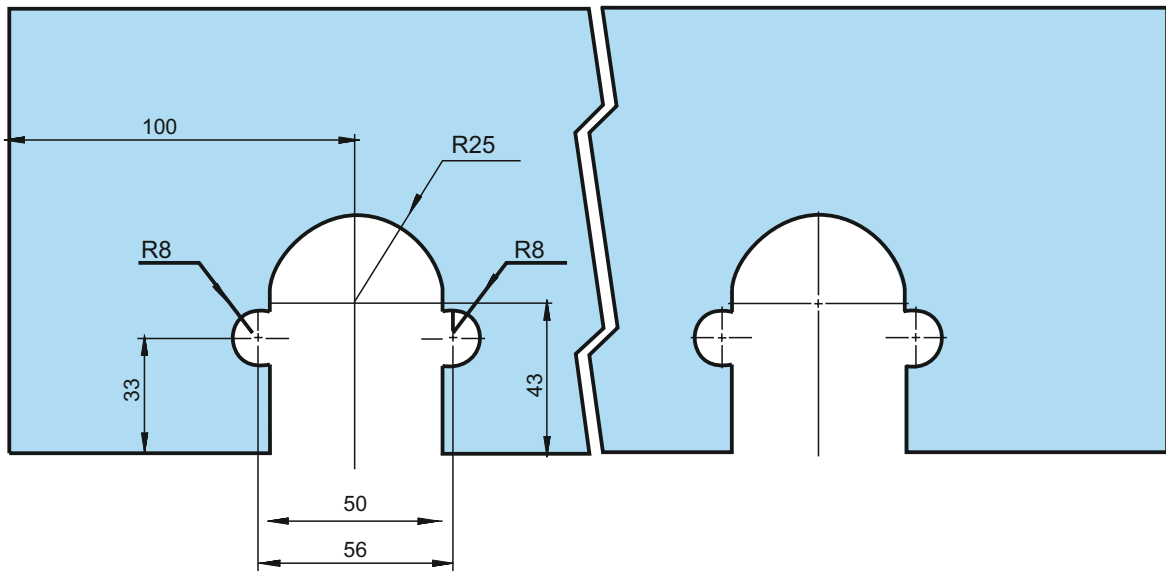

Floor guide

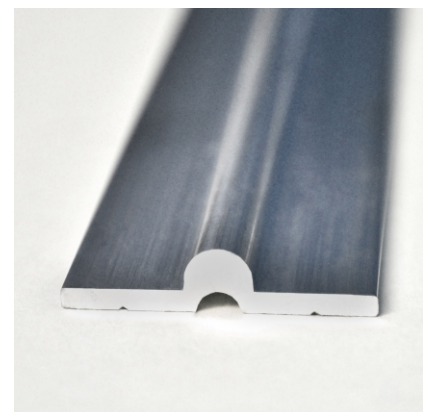
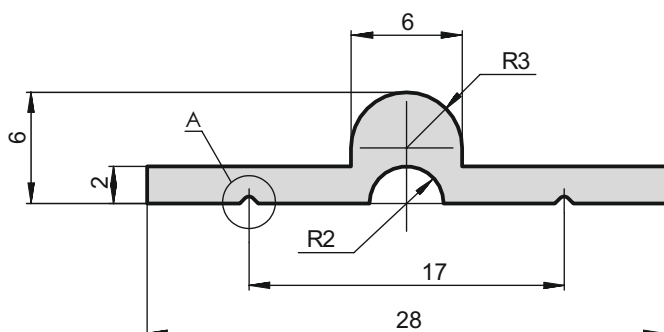

Sliding roller system with covered guide S-500

Design parameters

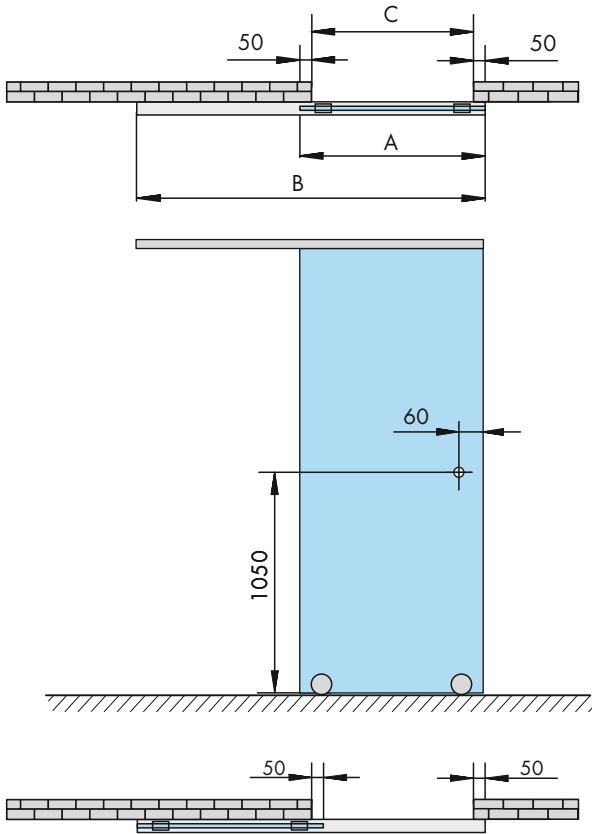

1-panel sliding system

$$A = C + 100$$

$$B = 2C + 100$$

$$H \text{ (wall mounting)} = Y + 16$$

$$H \text{ (ceiling mounting)} = Y - 14$$

C – opening width; A – door leaf width;

B – guide track length;

H – door leaf height; Y – opening height.

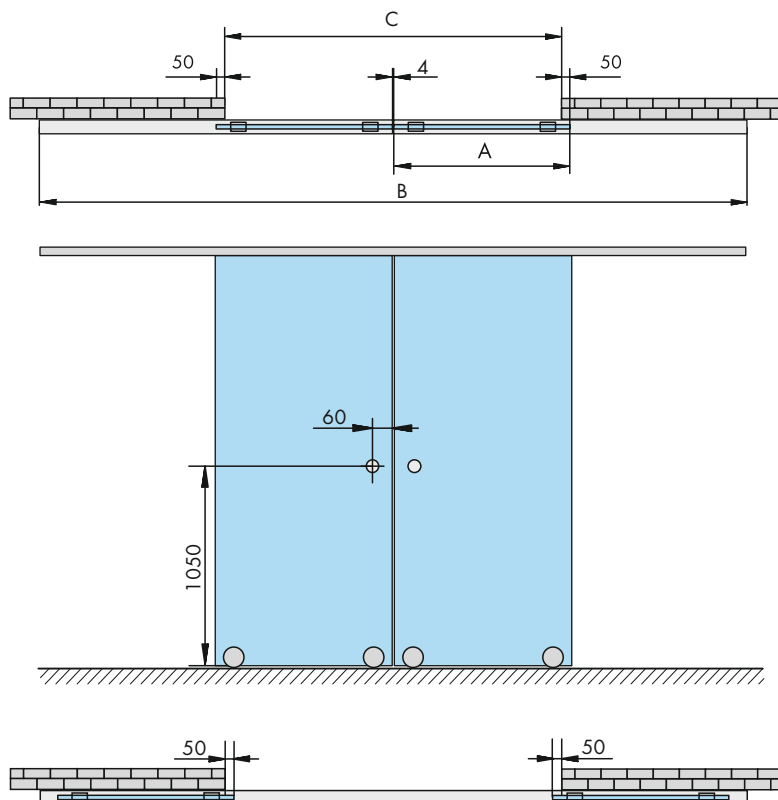

2-panel sliding system

$$A = C/2 + 48$$

$$B = 2C - 4$$

$$H \text{ (wall mounting)} = Y + 16$$

$$H \text{ (ceiling mounting)} = Y - 14$$

C – opening width; A – door leaf width;

B – guide track length;

H – door leaf height; Y – opening height

Handles for sliding systems SKLO+GLAS

Handles

Square handle

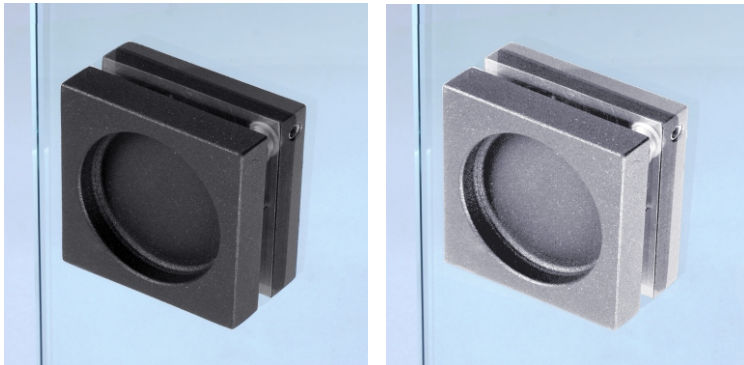

S-70g

S-70s

Glass front panel color

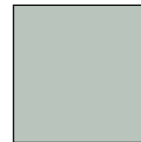

- Grey



- Black

Round handle



S-80g

S-80s

Drillings layout for handles

Square handle

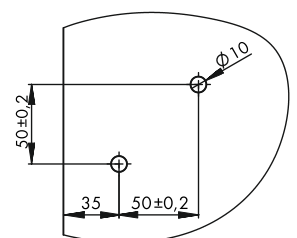
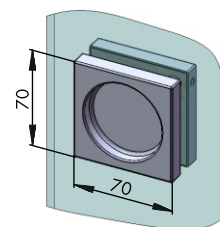

Round handle

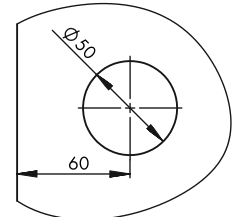
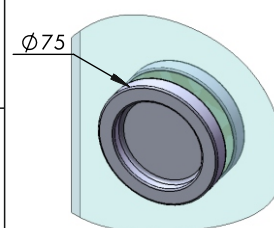

Rectangular handle

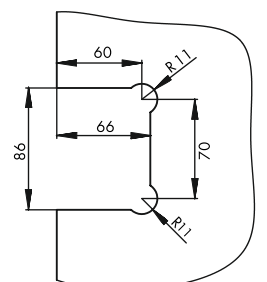
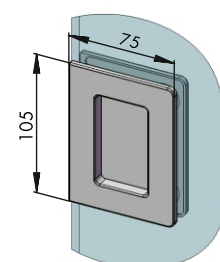

Rectangular handle

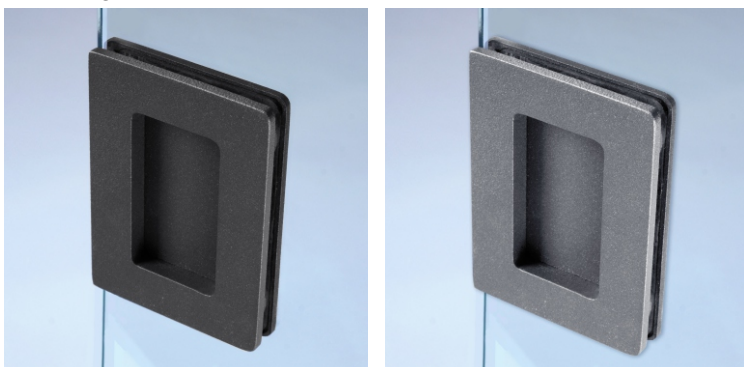

S-75g

S-75s

Measuring sheet for sliding doors

Opening: width, mm _____ height, mm _____ wall thickness, mm _____

Mounting type: wall mounting ceiling mounting mounting in opening

System type _____

Sliding profile: length, mm _____ end caps

Decorative cover: aluminium laminated glass color _____

single-sided double-sided

Leaf characteristics: glass laminated glass model _____ color _____

Overlapping of opening and door leaf, mm _____

Patterning: on front side on back side

Pattern characteristics: deep etching double-sided satin

milling according to drawing customer's design pattern development

Fittings: handle _____ lock _____

Notes: _____
